



CHESNEY'S

ALCHEMY RANGE OF GAS EFFECT FIRES
USER AND INSTALLATION INSTRUCTIONS FOR
DECORATIVE FUEL EFFECT APPLIANCES



THE WORLD'S LEADING SUPPLIER OF LUXURY FIREPLACES

www.chesneys.co.uk



Decorative Fuel Effect Appliances

Technical Manual
PIN: 0558CP1675

User and Installation Instructions

The Universal Burner for 22" Baskets
Burner Code: CUBB22



Available in Natural Gas

Contents

Section		Pages
1	Unpacking / Unit Parts	3
2	Technical Data	4-5
3	Installation Parameters	6-7
4	Installation	8-10
5	Burner Information	11-32
6	Clay Granules	33
7	Fibre coal / Log placement	34-38
8	Commissioning the fire unit	39
9	Briefing and handover to the customer	40
10	Servicing	41-44
11	Fault finding	45
12	User Instructions	46-55
	Fireguards	46
	Lighting the appliance	48-53
	Changing the Batteries	54
	Cleaning	55
13	Installer checklist	56
14	Dealer and Installer Information	56
	Annual Service Record	57
15	Warranty Registration	58

1. Unpacking

Remove the appliance from its packaging, and check that it is complete and undamaged.
If satisfied by the condition and the contents is as specified, proceed with the installation.

The installation should only be carried out by a competent person and all gas work must be carried out by a Gas Safe Registered person in accordance with national and local regulations for both gas and electricity (If required).
The installation must comply with local and national building regulations.

For the Republic of Ireland, reference should be made to IS813 and ICP3 and any guidance notes from Bord Gais.

Failure to comply with the regulations nullifies ALL guarantees.

Unit Parts

NG Logs (If supplied)



Embers / Glow Fibre (If supplied)



Clay Granules 1kg bag



Coals 2x Bags (If supplied)

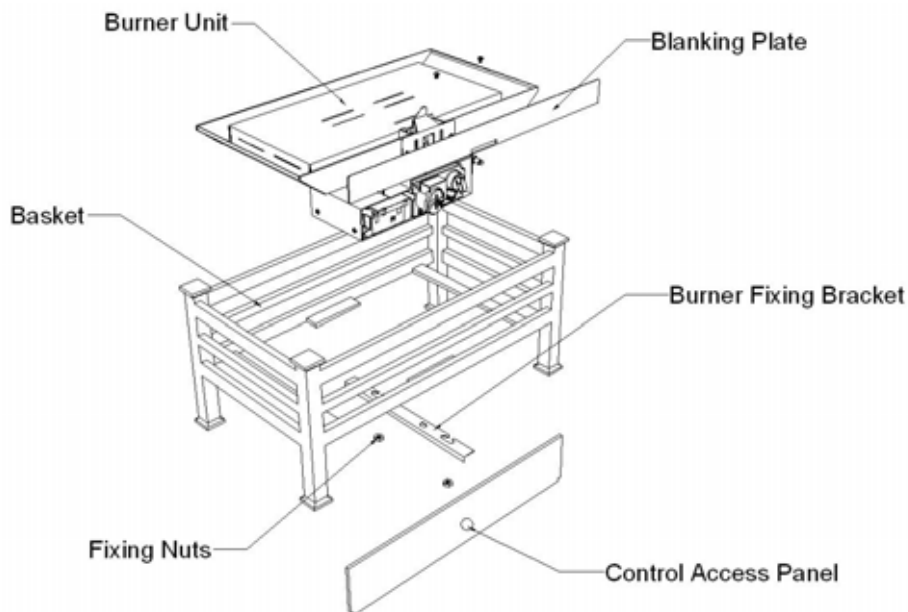
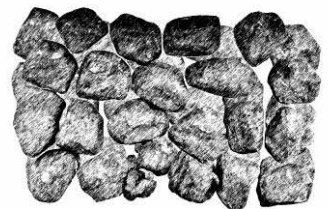

2. Technical Data

Oxypilot Assembly Marking	Natural Gas Burner : NG 9057
Gas Connection Size	8.0mm O.D. tubing
Minimum Flue Diameter (Millimetres/Inches)	178.0/7.0
Minimum Flue Height (metres)	4.0
Appliance Mass (kilograms)	3.6

Gas Type	Gas Category, Type And Supply Pressure	Countries of Destination																
		AT	BE	CH	CY	CZ	DE	DK	EE	ES	FI	FR	GB	GR	HU	IE	IT	LT
NG	I2H - G20 at 20mbar	✓		✓		✓		✓	✓	✓	✓		✓	✓		✓	✓	✓
	I2E - G20 at 20mbar						✓											
	I2E+ - G20 G25at20 25mbar		✓									✓						

Gas Type	Gas Category, Type And Supply Pressure	Countries of Destination										
		LU	LV	NL	NO	PL	PT	RO	SE	SI	SK	TR
NG	I2H - G20 at 20mbar		✓		✓		✓	✓	✓	✓	✓	✓
	I2E - G20 at 20mbar	✓				✓		✓				

Gas Type	Gas Category, Type And Supply Pressure	Injector (1 per appliance)		Heat Input kW, Gross (High / Low)	Burner Pressure (Hot) mbar (High/Low +/- 0.5mbar)
		Marking	Size		
NG	I2H - G20 at 20mbar	125	Multiholed 7x1.25mm	13.0, 14.0, 15.0, 16.0/8.5	8.9, 10.1, 11.4, 13.0/3.8
	I2E - G20 at 20mbar	125	Multiholed 7x1.25mm	13.0, 14.0, 15.0, 16.0/8.5	8.9, 10.1, 11.4, 13.0/3.8
	I2E+ - G20 G25at20 25mbar	125	Multiholed 7x1.25mm	13.0, 14.0, 15.0, 16.0/8.5	8.9, 10.1, 11.4, 13.0/3.8

3. Installation Parameters

The fire unit must be installed and used in accordance with these instructions.

This appliance is for decorative purposes.

For your safety it is law that all gas appliances must be installed by a competent person, in accordance with the current Gas Safety regulations applicable in the country of use.

The installation must be carried out in accordance with the relevant local and national specifications and comply with building regulations.

The following must comply with the requirements and satisfy Building Regulations – Approved Document J.

- ❖ Builders opening and Fire Chamber must be constructed of non-combustible material
- ❖ Hearth and clearance dimensions
- ❖ The minimum flue opening is 178mm (7") diameter 250 sq. cm. (38.5 sq. inches) and a minimum height of 3m (10ft), provided the flue which serves this appliance.

An in-line fan that complies with BS 5440: Part 1 can be used to improve flue draught.

NOTE - The flue must not be shared with any other appliance.

Prior to installation, ensure the compliance of local distribution conditions (E.g. The type of gas, pressure and the adjustment of the appliance) are compatible.

The builder's opening or fireplace opening must be constructed of a non-combustible material.

Before the fire is installed, the chimney should be swept and a flue test in accordance with National Regulations should be carried out.

The flue must be fitted in accordance with National Regulations, damper plates or flue restrictors must be removed or fixed permanently in the fully open position.

The gas connection must be in accordance with National Regulations.

The pilot light and flame sensing system fitted to this fire is also an atmosphere sensing device, this is not adjustable and must not be put out of action. If the pilot light is damaged or faulty it should be replaced only with the original identical unit supplied by Chesney's Limited.

Appropriate ventilation to the room where the appliance is to be fitted must be in accordance with Local and National Regulations and must be checked on a regular basis to ensure there is no obstruction.

This appliance must not be fitted in any room where steam is present (e.g. Bathroom).

The appliance is not fitted with an integral guard. It is recommended that a guard be used for the protection of young children, the elderly or infirm and also for normal use conforming to BS8423:2002, such that access to the flame is minimised.

It is advised not to stand too close to the appliance for prolonged periods of time; loose clothing is particularly at risk of burning due to the presence of an unguarded flame.

It is also advised against placing combustible materials directly in front of the appliance. Floor coverings, such as carpets, are considered to be acceptable.

Due to the newness of materials, the fire may give off a slight smell for a period of time after commissioning. This is quite normal and any odours should dissipate within a few hours of operation.

4. Installation

Check flue soundness

A smoke pellet can be used to test the flue for effectiveness of the draw, also checking other parts of the dwelling (including loft areas) for leakage, down-draught etc.

If the flue is unsatisfactory seek advice from a flue specialist.

NOTE – The smoke pellet gives a fair idea on the draw, but is no guarantee that the products of combustion from the fire unit will clear, this is also to be tested after the installation by carrying a spillage test.

Below is a guide to the flue diameter and minimum flue heights for different size openings.

NOTE - This table is a rough guide, due to some complex flue systems in some dwellings the suggested table may still be inadequate, contact a flue specialist for more advice.

Opening Width (mm)	Opening Height (mm)	Opening Width x Height	Floor to flue top height / Flue Diameter				
			Height 3.0m	Height 4.5m	Height 6.0m	Height 9.0m	Height 15.0m
350	550	1925cm ²	175 Dia.	175 Dia.	175 Dia.	175 Dia.	175 Dia.
400	550	2200cm ²	175 Dia.	175 Dia.	175 Dia.	175 Dia.	175 Dia.
460	460	2116cm ²	175 Dia.	175 Dia.	175 Dia.	175 Dia.	175 Dia.
460	550	2530cm ²	200 Dia.	175 Dia.	175 Dia.	175 Dia.	175 Dia.
460	610	2806cm ²	200 Dia.	200 Dia.	175 Dia.	175 Dia.	175 Dia.
610	460	2806cm ²	200 Dia.	200 Dia.	175 Dia.	175 Dia.	175 Dia.
610	610	3721cm ²	250 Dia.	225 Dia.	200 Dia.	200 Dia.	175 Dia.
610	760	4636cm ²	300 Dia.	250 Dia.	250 Dia.	225 Dia.	200 Dia.
760	460	3496cm ²	225 Dia.	225 Dia.	200 Dia.	200 Dia.	175 Dia.
760	610	4636cm ²	250 Dia.	250 Dia.	250 Dia.	225 Dia.	200 Dia.
760	760	5776cm ²	300 Dia.	300 Dia.	250 Dia.	250 Dia.	225 Dia.
760	910	6916cm ²	350 Dia.	300 Dia.	300 Dia.	250 Dia.	250 Dia.
910	460	4186cm ²	250 Dia.	225 Dia.	225 Dia.	200 Dia.	200 Dia.
910	610	5551cm ²	300 Dia.	300 Dia.	250 Dia.	250 Dia.	225 Dia.
910	760	6916cm ²	350 Dia.	300 Dia.	300 Dia.	250 Dia.	250 Dia.
910	910	8281cm ²	350 Dia.	350 Dia.	300 Dia.	300 Dia.	250 Dia.
910	1070	9737cm ²	*****	350 Dia.	350 Dia.	300 Dia.	300 Dia.
1070	460	4922cm ²	300 Dia.	250 Dia.	250 Dia.	225 Dia.	200 Dia.
1070	610	6527cm ²	300 Dia.	300 Dia.	300 Dia.	250 Dia.	250 Dia.
1070	760	8132cm ²	350 Dia.	350 Dia.	300 Dia.	300 Dia.	250 Dia.
1070	910	9737cm ²	*****	350 Dia.	350 Dia.	300 Dia.	300 Dia.
1070	1070	11449cm ²	*****	*****	350 Dia.	350 Dia.	300 Dia.
1070	1220	13054cm ²	*****	*****	*****	350 Dia.	350 Dia.
1220	460	5612cm ²	300 Dia.	300 Dia.	250 Dia.	250 Dia.	225 Dia.
1220	610	7442cm ²	350 Dia.	300 Dia.	300 Dia.	300 Dia.	250 Dia.
1220	760	9272cm ²	*****	350 Dia.	350 Dia.	300 Dia.	300 Dia.
1220	910	11102cm ²	*****	*****	350 Dia.	350 Dia.	300 Dia.
1220	1070	13054cm ²	*****	*****	*****	350 Dia.	350 Dia.
1220	1220	14884cm ²	*****	*****	*****	350 Dia.	350 Dia.
1520	460	6992cm ²	300 Dia.	300 Dia.	300 Dia.	250 Dia.	250 Dia.
1520	610	9272cm ²	*****	350 Dia.	350 Dia.	300 Dia.	300 Dia.
1520	760	11552cm ²	*****	*****	350 Dia.	350 Dia.	300 Dia.
1520	910	13831cm ²	*****	*****	*****	350 Dia.	350 Dia.
1520	1070	16264cm ²	*****	*****	*****	*****	350 Dia.
1520	1220	18544cm ²	*****	*****	*****	*****	*****

Check Ventilation

The appropriate size and type of ventilation into to the room where the appliance is to be fitted should also take into account any other gas appliances in the room and must comply with Local and National Regulations. The ventilation should be checked on a regular basis to ensure there is no obstruction.

Fitting the fire unit

The burner unit has been supplied in an assembled state with exception of clay granules and coals/logs. All Chesney's fire units have been tested to ensure safety.

Ensure that the gas supply is capable of delivering the required amount of gas, and is in accordance with the rules in force.

When laying the gas pipe work check the fire unit's gas inlet location to ensure a smooth run.

NOTE – All gas work must be carried out by a qualified gas installer to all relevant regulations.

An isolation valve or valves must be fitted adjacent to the appliance in accordance with national regulations this is to allow the complete removal of the burner control assembly, for maintenance or repair.

Chesney's fire baskets (Sold separately) are supplied with a grate; this is not needed for gas appliances and must be removed.



On certain types of fire baskets (mainly curved baskets) the right side grate structure bar must be removed to enable the fitting of the burner unit.



Secure the fire unit to the fire basket



When fitting the fire ensure that the unit is fitted under the flue opening so that no part of the fire bed protrudes beyond the fireplace opening.

Before connecting the fire unit purge the pipes from air and debris.

Light the fire on maximum and run for approximately 20mins and check that the hot burner pressure is in accordance with the values stated on pages 4 and 5 within the appliance specifications.

The Burner is fitted with a metal data plate supplied with the fire unit and is to remain with the fire unit for annual services.

Image of the data plate shown below:-



5. Burner Information

Remote / Manual versions



Dimensions

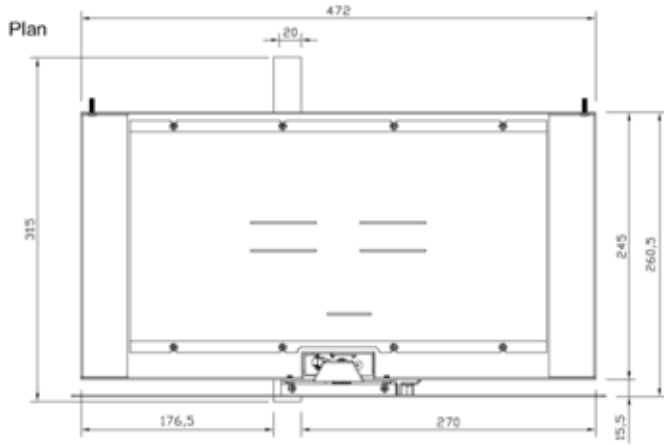

Perspective View

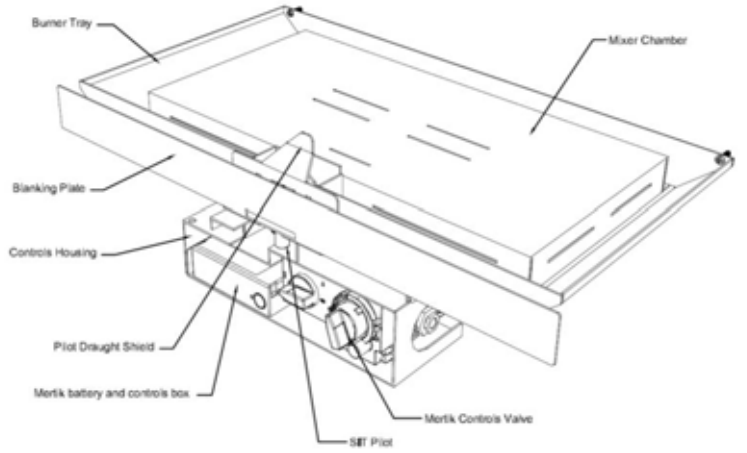

Front Elevation

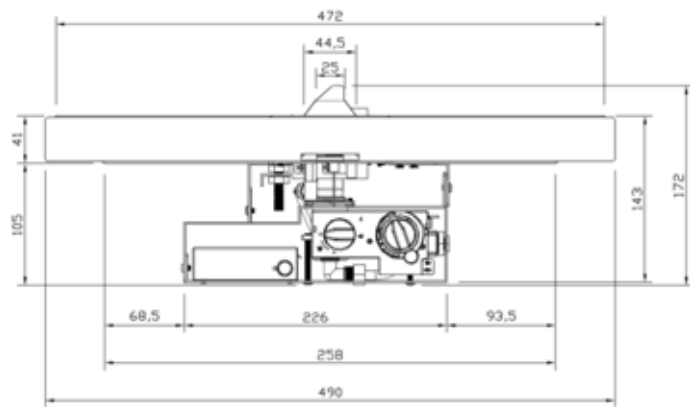

Side Elevation

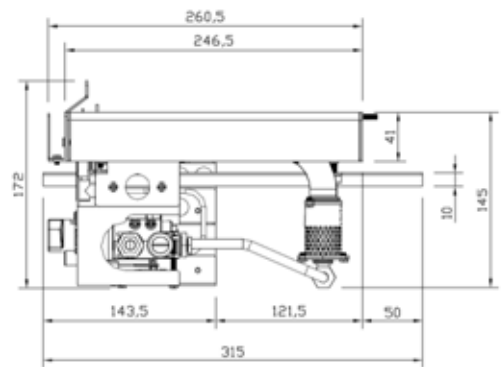

Control Valve – Mertik GV34 / GV36

NOTE – The GV36 does not have a motor attached but can be upgraded to the GV34.

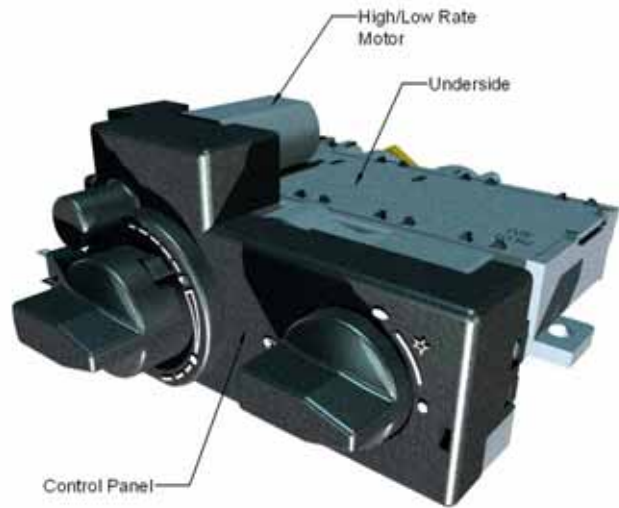
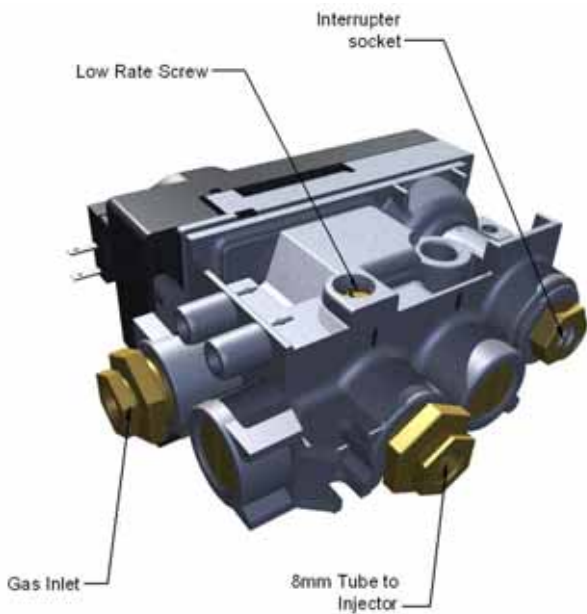
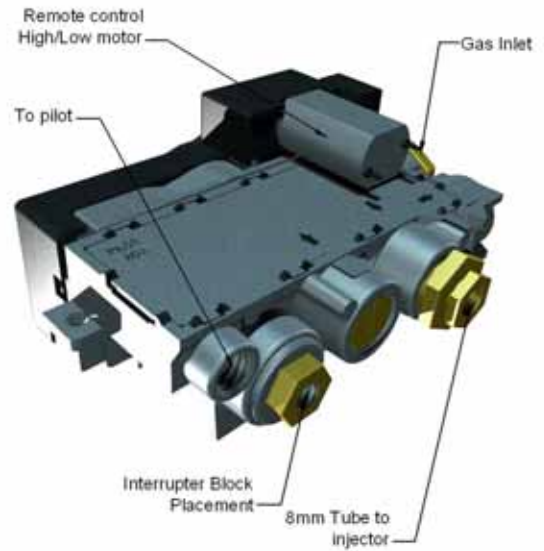
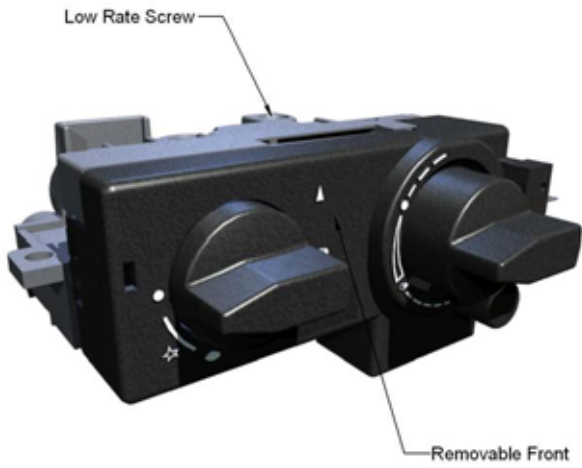

GV34 Wiring Diagram

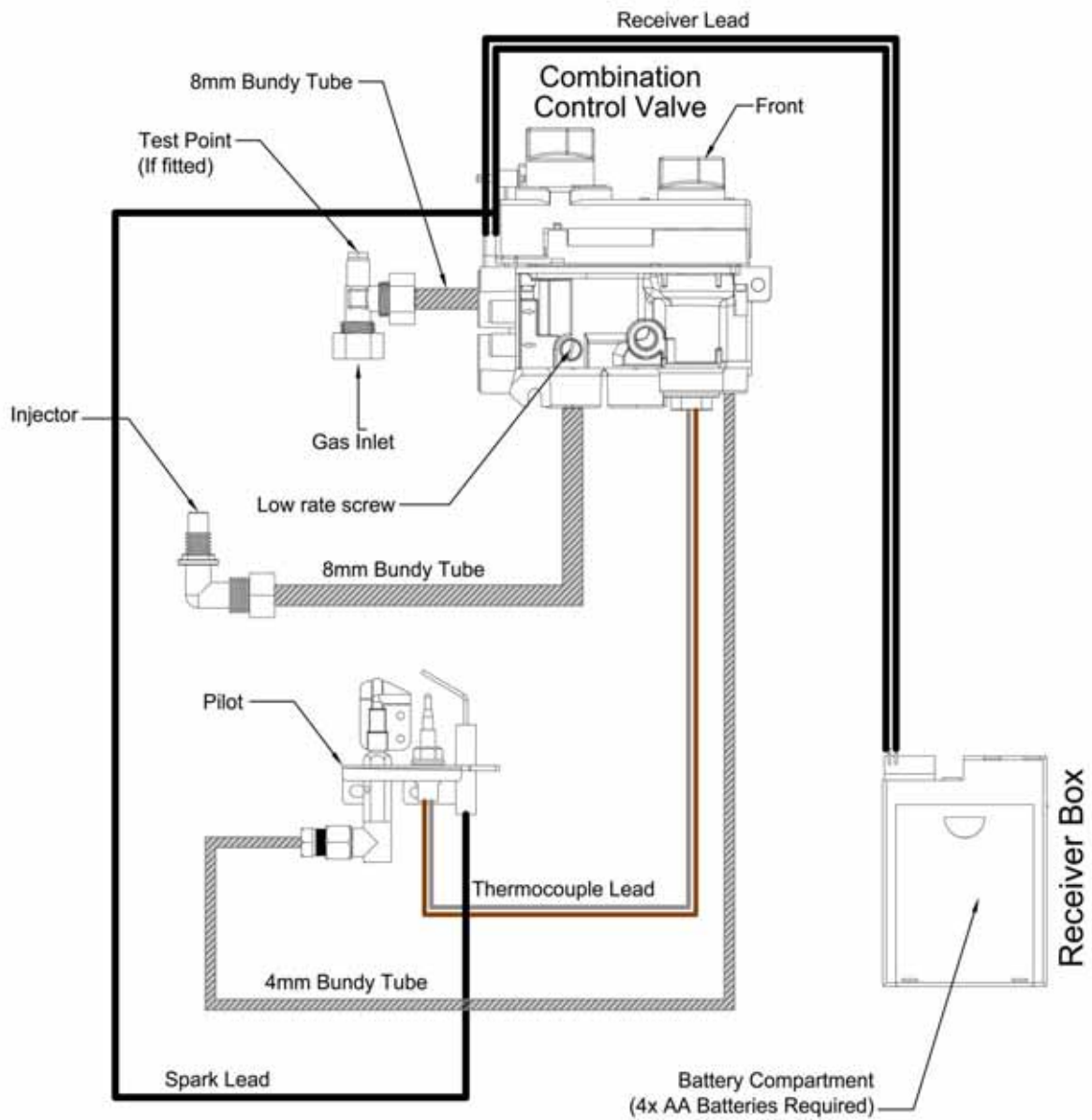

Control Valve – Mertik GV60 (Fully remote controlled)

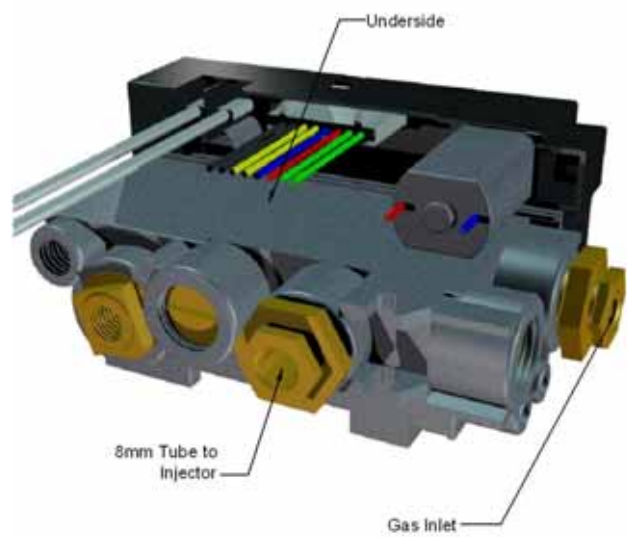
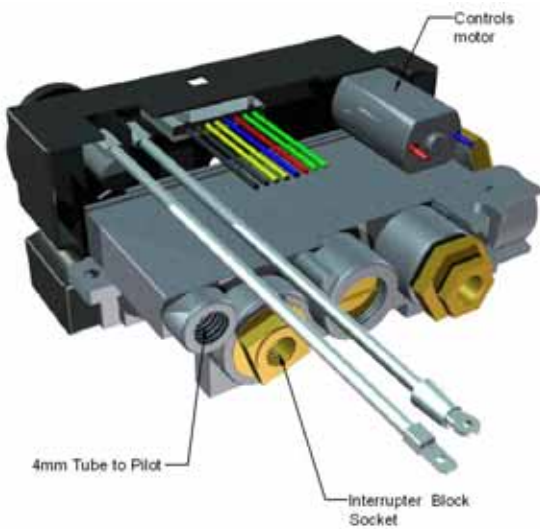
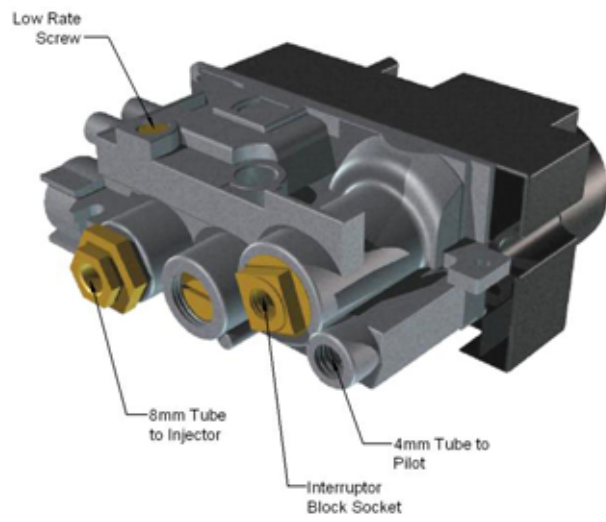
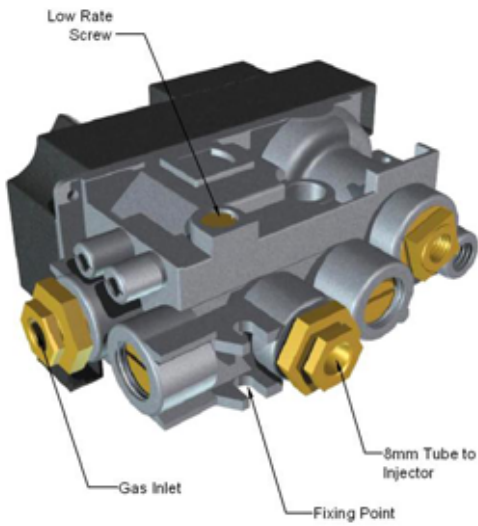
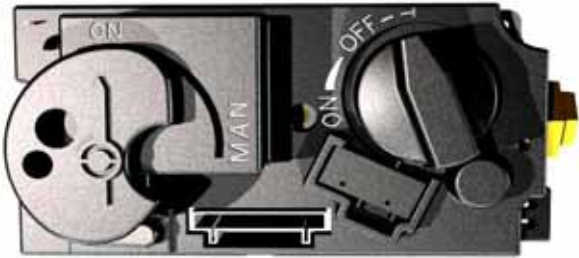

GV34 Remote Operated Gas Combination Controls



Features and Options

- No external electrical power required.
- Used with standard thermocouple and standard ODS pilot
- Flame height adjustment with remote control or switch
- Flame height knob may be adjusted manually, if required
- AGA, CGA and CE approvals
- Compact design with large capacity
- Thermoelectric flame failure device
- Safety interlock
- Pressure regulator or throttle
- Minimum rate selling with fixed or adjustable orifices
- Pilot gas adjustment screw
- Screen in the gas inlet area
- Side outlet for second burner (not motor controlled)

GV34, 36 and 60 models require no external electrical power to operate. The battery-powered motor allows main gas adjustment via an electric switch or remote.

In the event of a battery failure, the flame height may be adjusted by hand. The GV34 is configured for on-off low to high main burner function. The thermoelectric flame failure device functions with all standard thermocouple and ODS pilot burners (no powerpile necessary).



The GV34, 36, 60 Series multifunctional controls have been designed to be as interchangeable as possible. This allows the different functions to be realized in one heating appliance.

Technische Daten / Technical Data

max. Betriebsdruck:	50 mbar	Max. operating inlet pressure:	50 mbar
Durchfluß bei $\Delta P = 2,5$ mbar:	max. 1,2 m ³ /h Luft	Capacity at ΔP 2,5 mbar:	max. 1,2 m ³ /h air
GV35:	max. 1,4 m ³ /h	GV35:	max. 1,4 m ³ /h
Umgebungstemperatur:	0 ... 80 °C	Ambient temperature:	0 ... 80 °C
Druckregler:	Klasse C nach EN88	Pressure regulator:	class C according to EN88
	Einstellbereich 2,5 ... 20 mbar		adj. range 2,5 ... 20 mbar
Fernbedienung:		Remote:	
Ultraschall, Reichweite:	10 m	Ultrasonic, distance:	10 m
max. Umgebungstemperatur:	Empfänger & Sender 60 °C	Max. ambient temperature:	Receiver & Transmitter 60 °C
	Kabel 180 °C		Cable 180 °C
Batterien:	Empfänger: 4 x 1,5 V AA Alkaline	Batteries:	Receiver: 4 x 1,5 V AA alkaline
	Sender: 9 V Block		Transmitter: 9 V
	(Nutzungsdauer länger als eine Heizsaison)		(both sufficient for more than one heating season)

Operation

Lighting Procedure



- 1) Turn Knob **A** (figure 1) slightly left towards the ignition position  until reaching stop, press down and hold for five seconds (only pilot gas flows).
- 2) Continue pressing down knob **A** while turning further left to activate piezo, continue to hold down for 10 seconds after pilot has been lit. If pilot does not light, steps 1 and 2 can be repeated immediately.
- 3) Upon lighting, release knob and turn further left to ON  position. Pilot gas flows and main gas flows in accordance to the setting (Knob **B**).

Adjusting the flame height

To turn the fire on and/or to increase the flame height, press the ON button of the remote handset. Continue pressing until the desired flame height is obtained. Press and hold the OFF button to reverse the procedure. The receiver is equipped with a built-in delay, recognizable by the flickering light, to facilitate fine adjustment of the flame.

The motorized valve is equipped with a slip clutch, allowing manual adjustment of main gas by turning knob **B**.

Shut-off Procedure

- 1) Turn knob **A** right until reaching stop. In this position  only pilot gas flows.
- 2) To shut off the valve completely, press down slightly and continue turning right from pilot position to the OFF  position. The safety interlock prevents re-ignition of the pilot flame until the thermocouple has cooled down sufficiently (elapsed time will vary based on the thermocouple type).
- 3) Switching off the remote is not necessary.

Dimensions

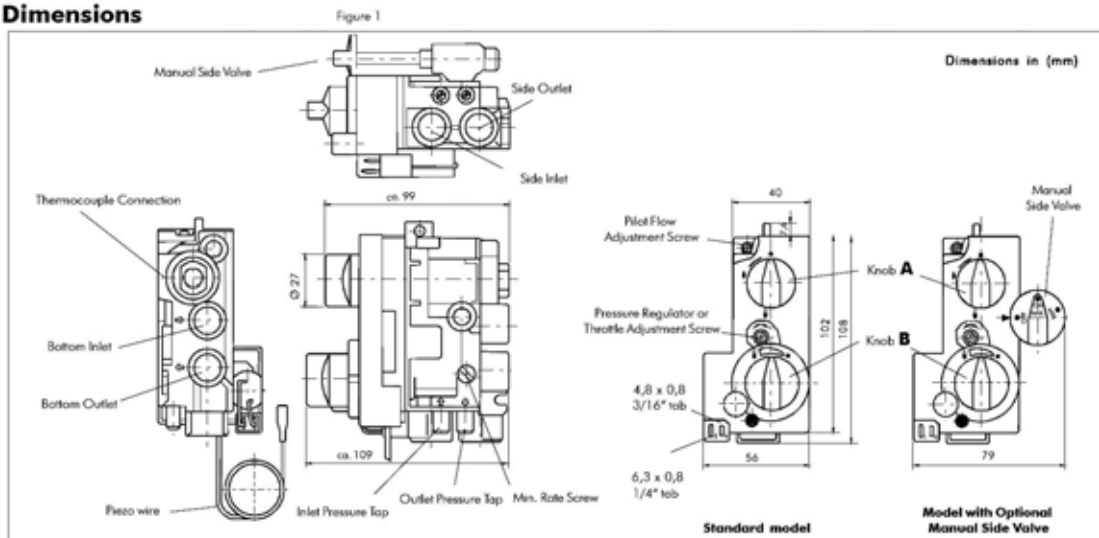

⚠ WARNING

Fire or explosion hazard. Attempted disassembly or repair of controls can cause property damage, severe injury or death. Do not disassemble the gas valve; it contains no serviceable components.

For your safety, read the user instructions before attempting to light the appliance.

Do not store or use gasoline or other flammable vapors and liquids in the vicinity of this control or other appliances.

WHAT TO DO IF YOU SMELL GAS

- Do not try to light any appliance.
- Do not touch any electrical switch; do not use any phone in your building.
- Immediately call the gas supplier from a neighbor's phone. Follow the gas supplier's instructions.
- If you cannot reach the gas supplier, call the fire department.

Installation and service must be performed by a qualified installer, service agency or the gas supplier.

The installation must conform with local codes or in the absence of local codes, with the National Fuel Gas Code, ANSI Z223.1/NFPA 54 or The International Fuel Gas Code or B149.1 in Canada. All piping and tubing must comply with local codes and ordinances.

Do not use this control or any gas appliance if any part has been under water or in contact with water. Immediately call a qualified service technician to replace the control system and any gas control which has been under water or in contact with water.

COMPONENTS

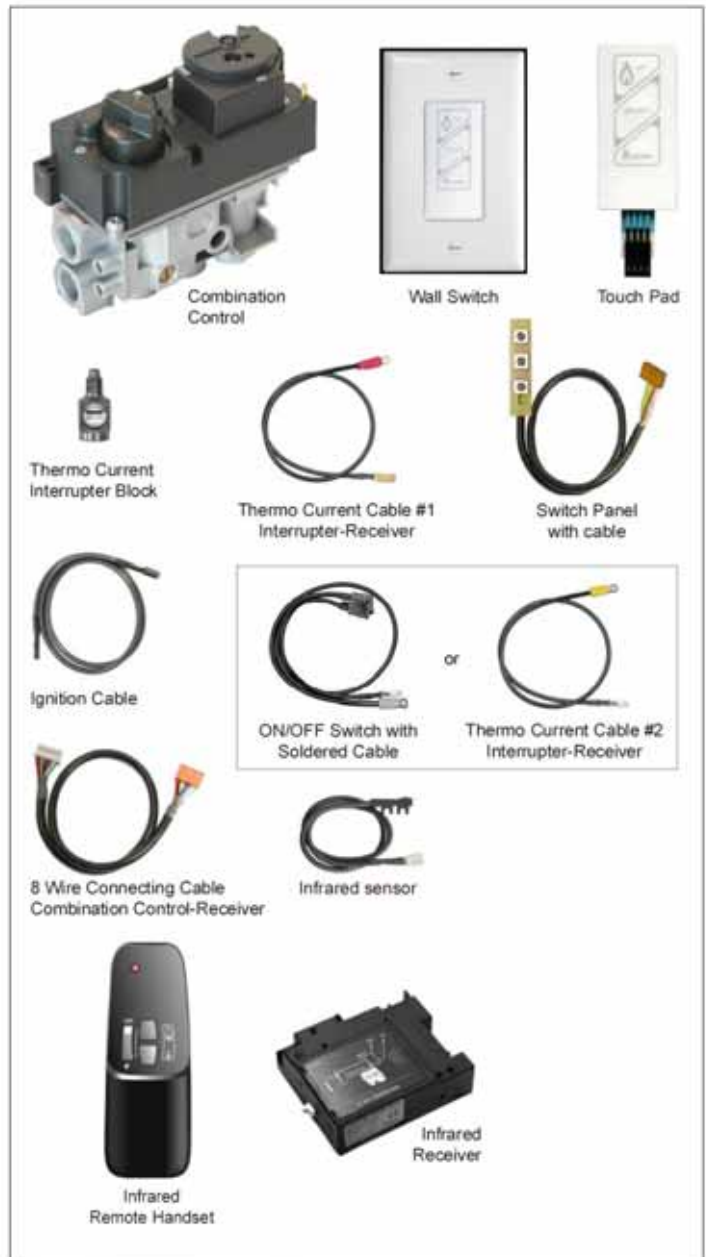

Figure 1: GV60 Components

The standard GV60 system consists of the following components (see figure 1).

Gas Combination Control (GV60 Series) with:

- ON/OFF switch with soldered cable or Thermo current cable #2 interrupter- receiver
- Thermo current cable #1 interrupter - receiver
- Thermo current interrupter block
- Ignition cable

Remote Control

- Remote handset and/or wall switch, switch panel, touch pad with 4 wire connecting cable
- Receiver
- 8 wire cable (connects valve to receiver)
- Infrared sensor (Infrared remote handsets only)

TECHNICAL SPECIFICATIONS

Gas combination control according to CSA or CE approval (see label for certification)

- Fuels:**
- CSA: Suitable for use with natural, manufactured, mixed and propane (LP) gases and LP gas-air mixtures
 - CE: Suitable for use with gases of EN 437 gas family 1, 2, and 3

Approvals:

- ANSI Z21.78/CSA 6.20 for U.S. & Canada.
- CE: Gas Appliances Directive 90/396/EEC and EN126

Pressure Drop/Capacity:

- CSA: 1" W.C. at 65,000 BTU/hr.
- CE: 2,5 mbar at 1,2 m³/h air

Range of Regulation:

- CSA: 10,000 to 85,000 BTU/hr.
- CE: Class C according EN88

Regulator Adjustment:

- CSA: 3" W.C. to 5" W.C. (7.5 to 12 mbar); 8" W.C. to 12" W.C. (20 to 30 mbar); 3" W.C. to 12" W.C. (7.5 to 30 mbar)
- CE: 5 to 40 mbar; 7,5 to 30 mbar

Max. Ambient Temperature:

32°F to 176°F (0°C to 80°C)

Mounting Position:

Mount valve 0° to 90°, in any direction (including vertically) from the upright position of the gas control knob.

Max. Inlet Pressure:

- CSA: 1/2 psi (34.5 mbar)
- CE: 50 mbar (20" W.C.)

Main Gas Connection:

- CSA: 3/8 in. NPT; Rp 3/8 ISO 7-1 internal thread for 12 mm, 10 mm, 8 mm, 6 mm outside diameter tube
- CE: Rp 3/8 ISO 7-1 internal thread for 12 mm, 10 mm, 8 mm, 6 mm outside diameter tube

Inlet and Outlet Connection:

at side or bottom

Pilot Gas Connection:

- CSA: 7/16-24 UNS for 1/4" or 3/16" tubing
- CE: M10x1 for 4 mm or 6 mm tubing

Thermocouple:

11/32 UNS, M10x1, M9x1, M8x1

Maximum allowed torque inlet and outlet:

- CSA: 280 inch-pounds
- CE: 35 Nm

Remote

NOTE: These remote handsets, receiver, wall switches, switch panels and touch pads are not interchangeable with previous versions.

Approvals:

- ANSI Z21.20/CSA 6.20 for U.S. & Canada.
- CE: Gas Appliances Directive 90/396/EEC and EN298-2003

Max. Ambient Temperature:

Remote Handset and Receiver: 140°F (60°C)
 Wall Switch/Touch Pad: 176°F (80°C)
 Switch Panel: 221°F (105°C)
 8 Wire Connecting Cable, Thermo Current Cable: 221°F (105°C)
 Ignition Cable: 302°F (150°C)

Batteries - Remote Handset:

1 x 9V block
 (quality alkaline recommended)

Batteries - Receiver:

4 x 1.5V "AA"
 (quality alkaline recommended)

An AC Mains Adapter may be used instead of batteries (only the Mertik Maxitrol AC Mains Adapter or one approved by Mertik Maxitrol can be used).

NOTE: During a power outage the AC Mains Adapter must be unplugged from the receiver to operate in the battery mode.

INSTALLATION INSTRUCTIONS

Read these instructions carefully. Failure to follow them could damage the product or cause a hazardous condition. These instructions are not to supersede the appliance manufacturer's instructions.

▲ WARNING

It is the appliance manufacturer's responsibility to determine GV60's suitability for a specific application.

▲ WARNING

Do not remove screws from the gas valve. Do not adjust and/or alter any components marked with tamper indicating paint; Motor knob is not to be removed.

▲ WARNING

Oxygen Depletion is a hazard and can cause injury or death due to asphyxiation. Use only components intended for vented gas appliances on vented appliances and unvented gas components on unvented gas appliances.

1. Turn off gas supply at the appliance service valve before starting installation, and perform a Gas Leak Test after the installation is complete.
2. Install the sediment trap (where required) in the gas supply line to prevent contamination of the gas valve.
3. Use only your hand to push in or turn the gas control knobs. Never use tools. If a knob will not push in or turn by hand, don't try to repair it, call a qualified service technician. Force or attempted repair will void warranty and can result in a fire or explosion.

Location

Locate the combination gas valve where it is not exposed to steam cleaning, high humidity, dripping water, corrosive chemicals, dust or grease accumulation or excessive heat. To assure proper operation, follow these guidelines:

- Locate combination gas valve in a well-ventilated area.
- Mount combination gas valve high enough to avoid exposure to flooding or splashing water.
- Make sure the ambient temperature does not exceed the ambient temperature ratings for each component.

▲ WARNING

GV60 standard version is suitable for indoor use only.

CONNECTIONS - MAIN AND PILOT GAS

▲ WARNING

Fire or Explosion Hazard. Can cause property damage, severe injury or death. Do not bend tubing at gas valve connection point after compression fitting has been tightened. This can result in gas leakage at the connection.

All piping must comply with local codes and ordinances or with the National Fuel Gas Code, ANSI Z223.1/NFPA 54 or The International Fuel Gas Code or B149.1 in Canada. Tubing installation must comply with approved standards and practices.

1. Use new, properly reamed pipe free from metal or material chips. When tubing is used, assure that ends are square, deburred and clean. All tubing bends must be smooth and free of distortion.
2. Run pipe or tubing to the valve.
3. Install a sediment trap (where required) in the supply line to the gas valve (see figure 2).

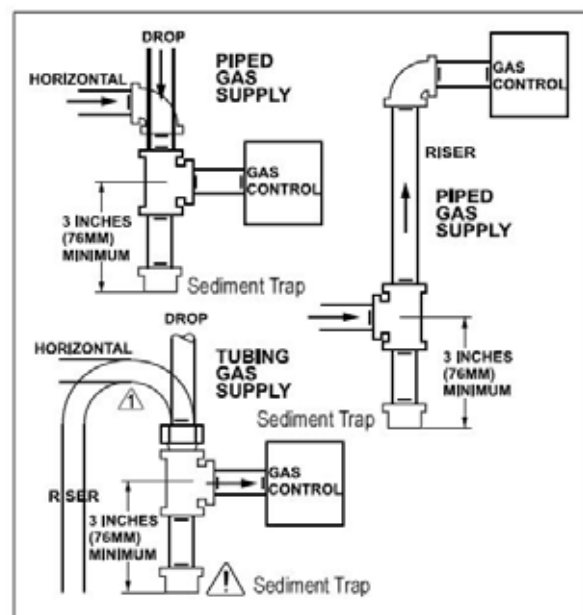

Figure 2: Sediment Trap (where required)

▲ WARNING

The main gas valve must be disconnected from the gas supply piping system during any pressure testing of the gas supply piping system at test pressures in excess of 1/2 psi (3.5 kPa CSA; 50 mbar CE).

Connection Main Gas (Tubing Connections)

1. Mount valve 0° to 90°, in any direction (including vertically) from the upright position of the gas control knob.
2. Slip nut and ferrule over tubing.
3. Insert tubing into inlet/outlet connection until it bottoms, slide ferrule and gland into place and turn finger tight. **Do not use pipe joint compound.**
4. Use a wrench to tighten gland about 1 turn beyond finger tight.

Connection Main Gas (Pipe Connections)

1. Mount valve 0° to 90°, in any direction (including vertically) from the upright position of the gas control knob.
2. Pipe to be inserted into the valve must be the proper thread length and to gauge. Thread that is cut too long can cause distortion or malfunction if inserted too deeply.
3. Apply a moderate amount of approved pipe sealant to the pipe only, leaving the two end threads bare. (Do not use Teflon® tape.)
4. Connect pipe to valve inlet and outlet. When threads are tightened, the valve must be held at the designated points (see figure 3). Do not apply pressure to top casting or plastic cover. Check all connections for leaks.

Connection Pilot Gas (Tubing Connections)

1. Ensure tubing end is square and free of burrs.
2. Insert pilot tubing into pilot outlet using fitting provided until it bottoms, and turn finger tight. **Do not use pipe joint compound.**
3. Turn with a wrench until you shear off the ferrule. Turn an additional 3/4 turn to make a gastight seal.
4. Connect other end of tubing to pilot burner according to the manufacturer's instructions.

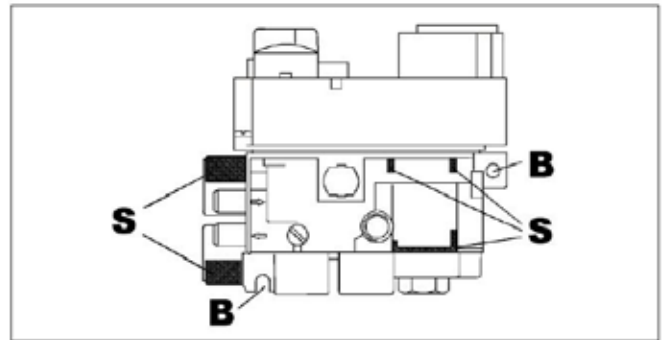

Figure 3: S=Clamp Areas, B=Mounting Points

PERFORM GAS LEAK TEST

▲ WARNING

Do not overtighten connections. Overtightening can damage the control body resulting in leakage or control malfunction.

1. Using a clean brush, apply an approved leak test solution to the pipe connections. Bubbles indicate a leak.
2. If a leak is detected, tighten pipe connections.
3. Light the main burner.
4. With the main burner in operation, apply an approved leak test solution to all pipe connections (including adapters) and the valve inlet and outlet. Bubbles indicate a leak.
5. If a leak is detected, tighten pipe connections (including adapters).
6. Replace parts if the leak cannot be stopped.

WIRING CONNECTIONS

▲ WARNING

Wiring of valve and receiver must be completed before starting ignition. Failure to do so could damage the electronics.

- Total resistance of thermocouple circuit should be minimized to assure proper operation.
- When GV60 components are installed, make sure they are not exposed to dirt, oil, grease or other chemical agents.
- Do not permit foreign particles under plastic cover.
- Wiring must comply with diagram.
- Place ON/OFF switch (if equipped) where it is easily accessible for the User.

Thermo Circuit

NOTE: The use of the Mertik Maxitrol interrupter block is recommended with the following connections. Keep connection of Interrupter Block and Thermocouple clean and dry. Avoid severe bending of the Thermocouple tubing during installation (min. 1" radius; 2.5 cm) as this may cause it to fail.

Fasten ring terminals from Thermo Current Cable #1 and Thermo Current Cable #2 (or optional ON/OFF Switch with Soldered Cable) tightly on the receiver with screws provided.

Install the interrupter block 1/4 turn more than hand tight into the valve. Insert the spade connectors in the slots (possible from both sides). Screw thermocouple hand tight into the interrupter block and tighten 1/4 turn to ensure a good electrical connection. Tighten only the thermocouple not the interrupter block.

Ignition Cable

NOTE: Do not damage the ignition cable while attaching it to the ignition electrode. When the cable is in place, avoid contact with sharp objects or edges.

With cables longer than 900 mm, avoid contact with metal parts, as this could decrease spark.

Attach ignition cable to receiver tab 2.8 x 0.8 mm (SPARK), and connect other side to ignition electrode.

Receiver

NOTE: To keep the receiver free from debris and dirt, do not remove the receiver from the plastic bag until all construction is complete.

During a power outage the AC Mains Adapter must be unplugged from the receiver to operate in the battery mode.

1. Snap the plug of the 8 wire cable in the receptacle on the valve and the receiver.
2. If used, connect 4 wire cable to receiver.
3. For infrared remote only: connect the infrared sensor to the receiver and place the eye in a suitable position. The infrared signal transmission requires a line of sight.
4. Insert batteries. Do not use metal tools. Using a metal tool could cause a short that may damage the receiver.
5. Place ON/OFF switch (if equipped) to ON position.
6. Check the reception. If necessary, correct position of antenna by moving the antenna cable to a position that allows for good reception.
7. When the RF-receiver is placed in the appliance, the surrounding metal can reduce reception considerably. The position of the antenna on the receiver also influences reception.
8. **The antenna must not come in contact or cross the ignition wire, this may render the receiver inoperable.**

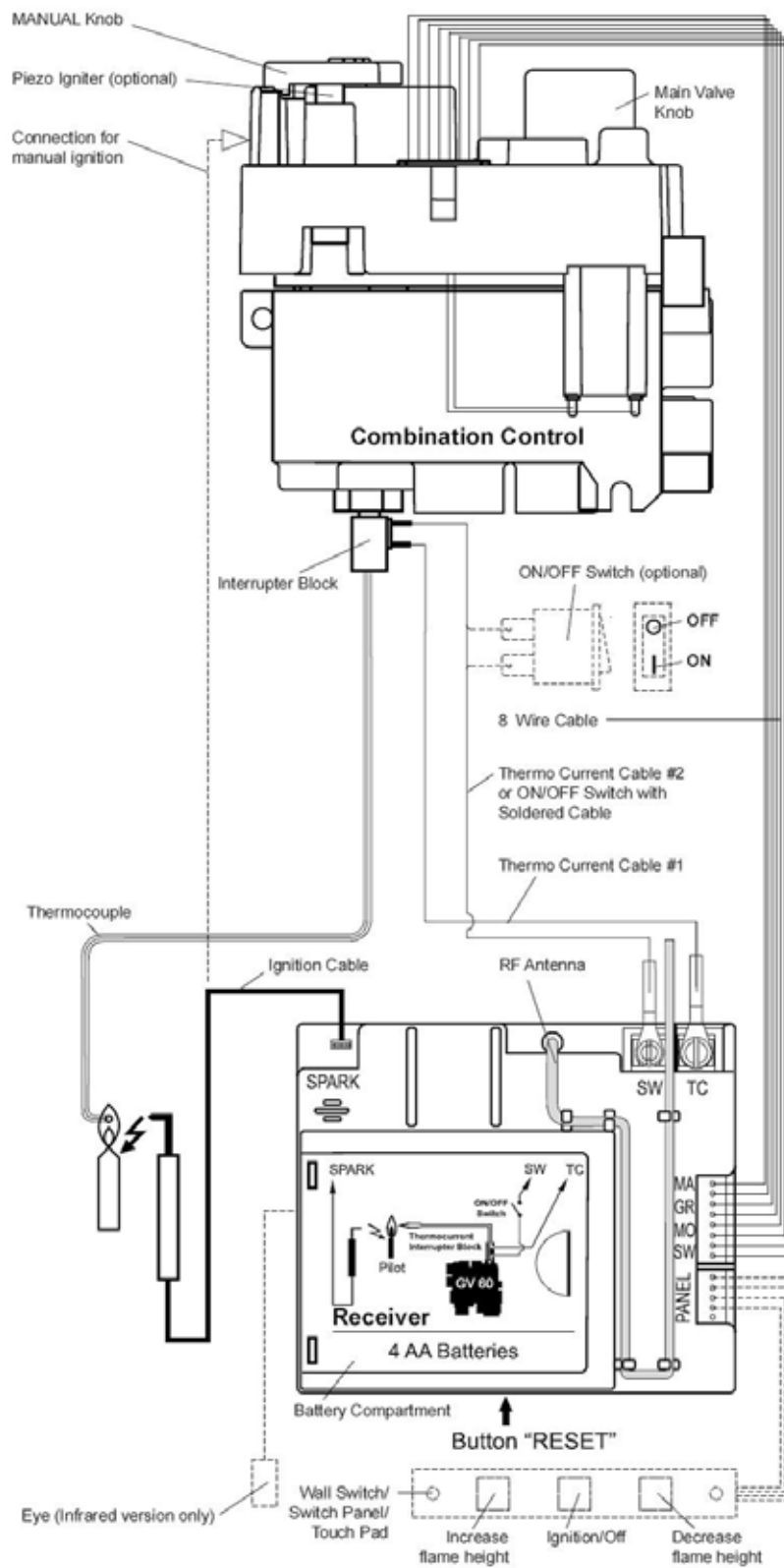

Figure 4: Wiring Diagram

GAS CONTROL KNOB SETTINGS

Gas control knobs function as follows (see figure 5):

KNOB	POSITION	FUNCTION
Main valve	OFF	Prevents main gas flow through valve.
Main valve	ON	Permits main gas flow through valve if the pilot is lit and thermocouple is generating sufficient power.
MANUAL knob	MAN	Allows the pilot to be manually ignited and prevents main gas flow.
MANUAL knob	ON	Allows for automatic ignition.

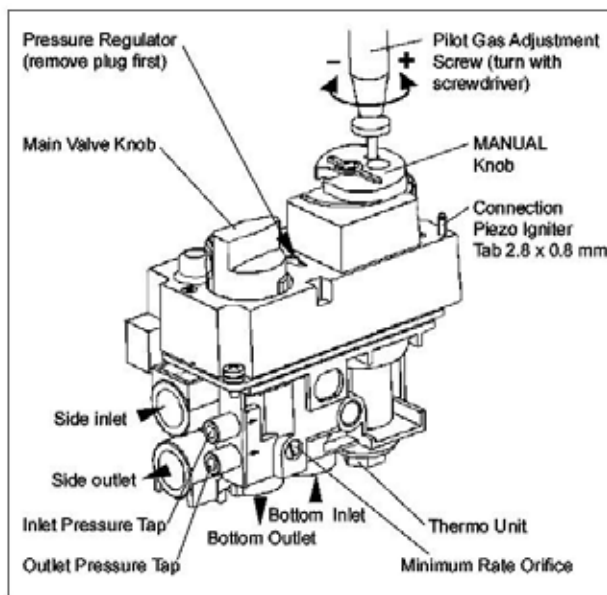

Figure 5: Combination Control GV60, Connections and Adjustment Options

ADJUSTMENT

▲ WARNING
Do not adjust ODS (vent free) pilot.

▲ WARNING
It is the appliance manufacturer's responsibility to determine GV60's suitability for a specific application.

▲ WARNING
Do not attempt to remove screws from the top of gas valve. Do not change any adjustments marked with tamper indicating paint; Motor knob is not to be removed.

▲ WARNING
Oxygen Depletion is a hazard and can cause injury or death due to asphyxiation. Use only components intended for vented gas appliances on vented appliances and unvented gas components on unvented gas appliances.

Pilot Flame Adjustment

The pilot flow adjustment is pre-set to maximum at the factory. The pilot flame should envelope 3/8" to 1/2" of the thermocouple - vented only (see figure 6).

1. The adjustment screw can be reached through a hole in the MANUAL knob (see figure 5).
2. Turn the MANUAL knob to the ON position.
3. It is now possible to pierce through a film on the cover with a screw driver to reach the adjustment screw beneath.
4. Turn the adjustment screw clockwise ↻ to decrease or counterclockwise ↻ to increase pilot flame.

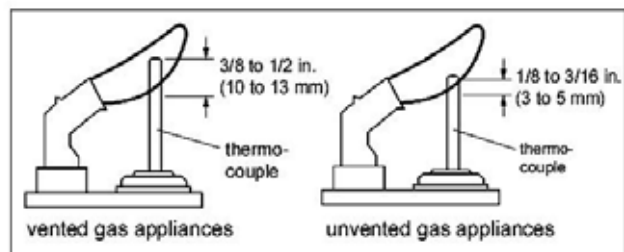

Figure 6: Proper Flame Impingement on Thermocouple

Outlet Pressure Adjustment

Pressure regulator or throttle are located under the cover and can be reached by removing the plug (see figures 5 and 7).

▲ WARNING
Do not exceed the input rating stamped on the appliance nameplate, or the manufacturers recommended burner orifice pressure for size orifice(s) used.

▲ WARNING
For complete combustion, be sure the primary air supply to the main burner is adjusted properly. Follow the instructions of the appliance manufacturer.

1. Connect a pressure manometer to the valve outlet pressure tap. Pressure tap is opened by turning the screw counterclockwise ↻.
2. To access regulator adjustment remove plug first (figures 5 and 7).
3. Turn MANUAL knob and main valve knob to the ON position.
4. Turn pressure regulator adjustment screw, accessible through opening in top of cover, to set required burner pressure (high fire). Pressure is increased by turning clockwise ↻ (pressure regulator models), or decreased by turning counterclockwise ↻.

NOTE: Throttle models pressure is increased by turning counterclockwise ↺; or decreased by turning clockwise ↻.

5. After adjustment, replace the plug.
6. If no other adjustments are required, close pressure tap(s) by turning the screw(s) full clockwise ↻. Check all connections/pressure tap(s) for leaks.
7. If the desired outlet pressure or flow cannot be achieved by adjusting the gas valve, check the gas valve inlet pressure using a manometer at the valve inlet pressure tap. If the inlet pressure is in the normal range, replace the gas valve; otherwise, take the necessary steps to assure proper gas pressure to the valve.

Minimum Gas Flow Adjustment (for CE Use only)
(see figure 5)

1. Set the control into low fire setting by turning the motor knob in OFF-position and back until the valve opens.
2. The minimum rate can be set either by screwing in a calibrated minimum rate screw (fixed orifice) or an adjustable minimum rate screw. Controls with adjustable screws without a customer specific setting are factory set at maximum flow.
3. Turn the screw clockwise to decrease the minimum flow.
4. Care should be taken to screw the fixed orifice until it stops.
5. Close pressure tap(s) by turning the screw(s) full clockwise ↻. Check all connections/pressure tap(s) for leaks.

Changing the Fuel Type (for CE use only)

GV60 is suitable for all gas types and can be converted to meet the manufacturer's requirements for a specific gas type. Adjustments of pressure regulator, minimum rate and pilot gas are according to above-mentioned instructions.



Figure 7: Combination Control GV60, Cover

FINAL CHECK

Observe several complete cycles to ensure proper operation. During these cycles the electronics will determine the optimum ignition sequence timing.

1. **STOP!** Read the safety information included before proceeding.
2. Turn main valve knob to the **OFF**, full clockwise ↻ position.
3. Place ON/OFF switch (if equipped) to the **O** (OFF position).
4. Wait five (5) minutes to clear out any gas. Verify that no gas is in the area around the appliance, including near the floor. **If you detect gas STOP! Follow "A" in the safety information of the Operating Instructions.** If no gas is present, proceed according to the Mertik Maxitrol Operating Instructions GV60-OI-EN.

▲ WARNING

Fire or explosion hazard. Attempted disassembly or repair can cause property damage, severe injury or death. Do not disassemble the gas valve; it contains no serviceable components.

MERTIK MAXITROL®

GV60 Remote Electronic Ignition and Control System



OPERATING INSTRUCTIONS - FOR OEM USE ONLY



Figure 1



Figure 2



Figure 3



Figure 4

▲ WARNING

Fire or explosion hazard. Attempted disassembly or repair of controls can cause property damage, severe injury or death. Do not disassemble the gas valve; it contains no serviceable components.

If the information in this manual is not followed exactly, a fire or explosion may result causing property damage, personal injury or loss of life.

A. **BEFORE OPERATING** verify that no gas is in the area around the appliance, including near the floor.

WHAT TO DO IF YOU SMELL GAS:

- Do not try to light any appliance.
- Do not touch any electrical switch; do not use any phone in your building.
- Immediately call the gas supplier from a neighbor's phone. Follow the gas supplier's instructions.
- If you cannot reach the gas supplier, call the fire department.

B. Use only your hand to push in or turn the gas control knobs. Never use tools. If a knob will not push in or turn by hand, don't try to repair it, call a qualified service technician. Force or attempted repair may result in a fire or explosion.

C. Do not use this control or any gas appliance if any part has been under water or in contact with water. Immediately call a qualified service technician to replace the control system and any gas control system which has been under water or in contact with water.

D. These instructions are to be referenced as a user guide, and do not supersede appliance manufacturer's lighting instructions.

APPLICATION

GV60 is a battery-powered electronic remote ignition and control system for gas appliances with pilot burners and ODS systems.

GENERAL NOTES

Batteries - Remote Handset:

1 x 9V block (quality alkaline recommended)

Batteries - Receiver:

4 x 1.5V "AA" (quality alkaline recommended)

An AC Mains Adapter may be used instead of batteries (only the Mertik Maxitrol or an AC Mains Adapter approved by Mertik Maxitrol can be used).

NOTE: During a power outage the AC Mains Adapter must be unplugged from the receiver to operate in the battery mode.

APPLICATION

GV60 is a battery-powered electronic remote ignition and control system for gas appliances with pilot burners and ODS systems.

GENERAL NOTES

Batteries - Remote Handset:

1 x 9V block (quality alkaline recommended)

Batteries - Receiver:

4 x 1.5V "AA" (quality alkaline recommended)

An AC Mains Adapter may be used instead of batteries (only the Mertik Maxitrol or an AC Mains Adapter approved by Mertik Maxitrol can be used).

NOTE: During a power outage the AC Mains Adapter must be unplugged from the receiver to operate in the battery mode.

Infrared Remote Handset (see figure 5)

- Simultaneously press and hold ✳ (star) and 🔥 (large flame) until a short acoustic signal confirms the start sequence has begun; release buttons.
- Continuing signals confirm the ignition is in process
- Once pilot ignition is confirmed, there is main gas flow.

Wall Switch/Touch Pad/Switch Panel (see figure 6)

- Press and hold button "B" (see figure 6) until a short acoustic signal confirms the start sequence has begun; release button.
- Continuing signals confirm the ignition is in process.
- Once pilot ignition is confirmed, there is main gas flow.

NOTE: If the pilot does not stay lit after several tries, turn the main valve knob to **OFF** and follow the instructions "Turn Off Gas to Appliance"



Figure 5. Infrared Remote Handset

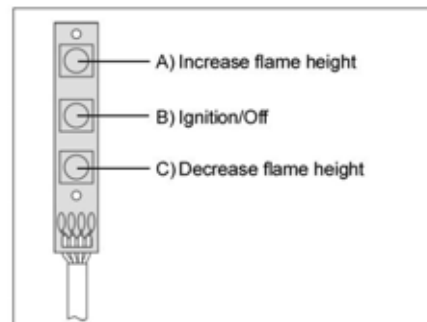

Figure 6. : Wall Switch/Touch Pad/Switch Panel

TO TURN OFF APPLIANCE

Press **OFF** button on remote handset. Press **ON/OFF** button on wall switch and touch pad. Press **OFF** on switch panel (see figure 6, button "B").

NOTE: Press  (small flame) to turn main gas to pilot gas.

TO OPEN AND CLOSE SOLENOID VALVE/BURNER

NOTE: The latching solenoid valve will not operate for one minute after ignition.



The latching solenoid valve cannot operate manually. If the battery runs down it will remain in the last operating position. During normal operation the solenoid valve will be reset into the ON position when the GV60 is switched OFF remotely.

- Upon ignition both Burner and Decorative Burner are ON.
- Press upper left and lower right button simultaneously to switch the Burner OFF (printed instructions are located on the battery cover, see figure 7).
- Press upper left and upper right button simultaneously to switch the Burner ON. (Display and Timer/Thermostat Remote Handsets: the AUX symbol on the display will indicate that the solenoid valve is OPEN.)



Figure 7: Instructions for Latching Solenoid Valve

Infrared Remote Handset (see figure 5)

- To increase flame height press  (star) and  (large flame) buttons simultaneously.
- Press  (small flame) to decrease flame height or to set appliance at pilot flame.
- For fine adjustment tap the star and large flame or small flame. There is a separate **OFF** button.

Wall Switch/Touch Pad/Switch Panel (see figure 6)



- Press button "A" to increase flame height.
- Press button "C" to decrease flame height or set appliance at pilot flame.
- For fine adjustment tap the button "A" or "C".

NOTE: If the appliance will not operate, follow the instructions "TURN OFF GAS TO APPLIANCE".

MANUAL OPERATION (see figures 8, 9)

Follow appliance manufacturer's instructions for gaining access to the gas control and the pilot burner. Access to the pilot burner is only required for ignition with a match.

When turning main valve knob, do not force. Knob has a slip clutch that clicks until the end stops are reached. This allows for manual flame height adjustment as well as adjustment to pilot standby position.

1. **STOP!** Read the safety information included before proceeding.
2. Turn main valve knob to the **OFF**, full clockwise  position.
3. Turn **MANUAL** knob to the **MAN**, full clockwise  position.
4. Place ON/OFF switch (if equipped) in **O** (OFF position).
5. Wait five (5) minutes to clear out any gas. Verify that no gas is in the area around the appliance, including near the floor. **If you detect gas STOP!** Follow "A" in the safety information. If no gas is present, proceed to step 6.
6. Place ON/OFF switch (if equipped) in **I** (ON position).

- With the MANUAL knob in **MAN** position a manual pilot valve operator and piezo igniter (optional) are accessible.

Ignition with match:

Fully push down manual pilot valve operator and hold in, to start pilot gas flow.

Immediately light the pilot with a match, while continuing to hold in the manual pilot valve operator for about one (1) minute after the pilot is lit. Release manual pilot valve operator. If pilot does not stay lit, wait five (5) minutes and repeat.

Ignition with piezo igniter:

Change the ignition cable from the receiver to the valve (see figures 8 and 10). Use the push piezo igniter to ignite. If pilot does not stay lit, wait five (5) minutes and repeat.

NOTE: If the pilot does not stay lit after several tries, turn the gas control knob (main valve knob) to **OFF** and proceed to step 11.

- If applicable, per appliance manufacturer's instructions, replace pilot access panel before proceeding.
- Turn MANUAL knob to the **ON**, full counterclockwise position.
- Turn main valve knob to the full **ON**, full counterclockwise position.
- If the appliance will not operate, follow the instructions "TURN OFF GAS TO APPLIANCE" and call the service technician or gas supplier.

TURN OFF GAS TO APPLIANCE

- Press **OFF** button on remote or wall switch/touch pad/switch panel.
- Follow appliance manufacturer's instructions for gaining accessibility to the gas control.
- Place ON/OFF switch (if equipped) in **O** (off position).
- Turn main valve knob to the **OFF** full clockwise position.
- Replace appliance accessibility cover (if applicable), per appliance manufacturer's instructions.

NOTE: With very low battery the GV60 system shuts off the fire completely. This will not happen if the power supply is interrupted.

Battery replacement

Battery replacement is recommended at the beginning of each heating season. Do not use metal tools to remove batteries. Using a metal tool could cause a short that may damage the receiver.

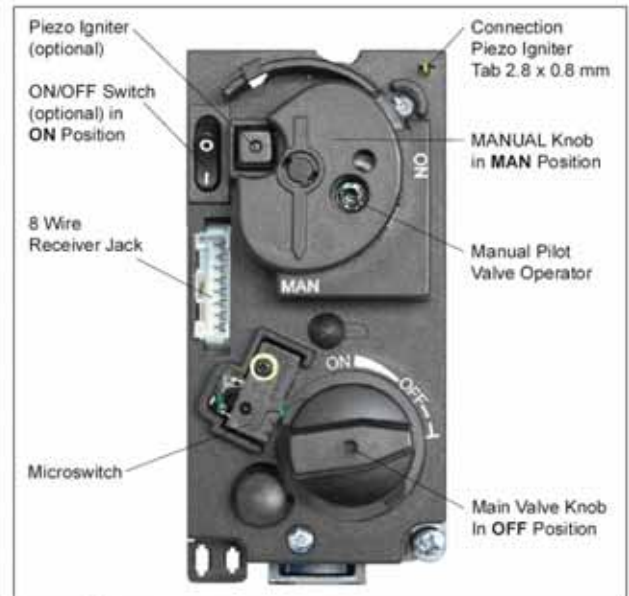

Figure 8 : Combination Control, Cover



Figure 9 : Combination Control, View MANUAL knob

GV60 Wiring Diagram

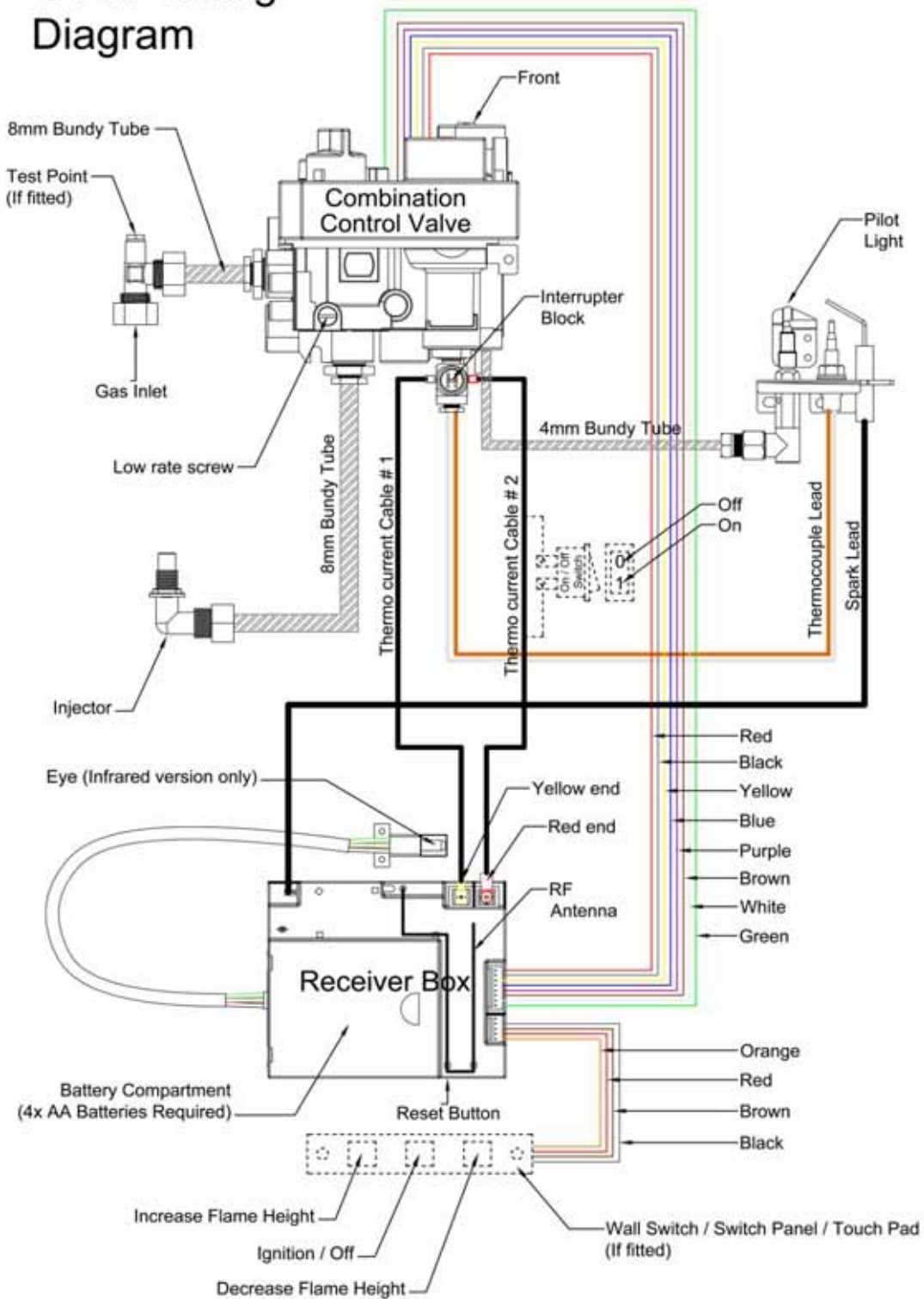

Figure 10: Wiring Diagram.

Remote Control Sets

With Flame Height Adjustment

For Fireplaces, Gas Space Heaters and Patio Heaters

- Battery powered, no external power required
- Compact receiver design
- Remote control with two button operation prevents accidental lighting (per GAD90/396/CE)

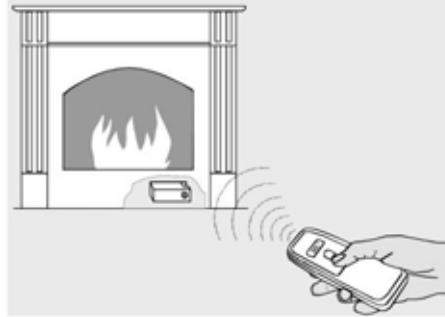

Technical Data

Ultrasound transmission	Frequency:	ON 40,5kHz, OFF 40kHz	Caution, if the appliance is left unattended in the on position extraneous sound waves can activate the ultrasonic receiver and change the flame height adjustment.
Ambient temperature range	Working Range:	1,6'/0,5 to 32,8'/10m	
Batteries	Remote and Receiver:	max. 140°F / 60°C	
Connecting cable	Connecting cable:	max. 356°F / 180°C	
	Quality Alkaline:	Remote: 1 x 9 V Block Receiver: 4 x 1,5 V AA	
	Standard length:	31.5" / 0,8m	

Mertik Maxitrol GmbH & Co. KG
Warnstedter Str. 3, 06502 Thale, Germany
Tel.: +49-3947-400-0, Fax: +49-3947-400-200

Mertik Maxitrol GmbH & Co. KG - Branch Office
Industriestrasse 1, 48308 Senden, Germany
Tel.: +49-2597-9632-0, Fax: +49-2597-9632-99

www.mertikmaxitrol.com

SIT Pilot – NG9057

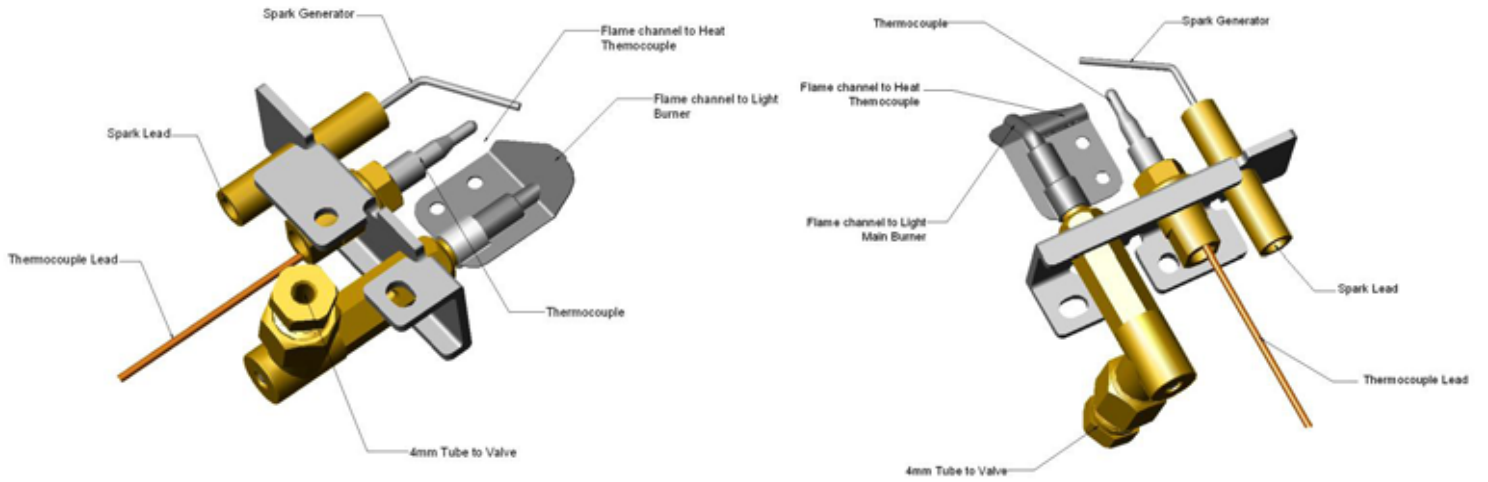

NG Injector – 7 holes drilled at 1.25mm

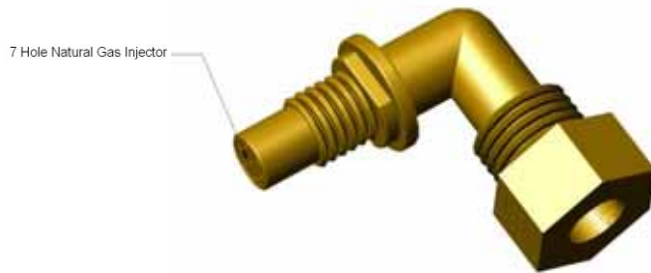

6. Clay Granules

Clay granules are used to fill the fire bed.

Carefully pour the granules on to the bed of the burner unit ensuring not to compress the granules when levelling them into the bed of the burner tray, also make sure it is spread evenly across the top.

Granules



7. Fibre coal / Log placement

The fire unit is approved for use with fibre coals or logs.

The fire unit has a certain amount of fibre coals / logs placed on the burner unit.

It is advisable not to add more fibre coals / logs onto the fire bed than specified as this will affect the emissions.

There are 30 coals for the 22" basket burner.

Coal Placement

Base layer

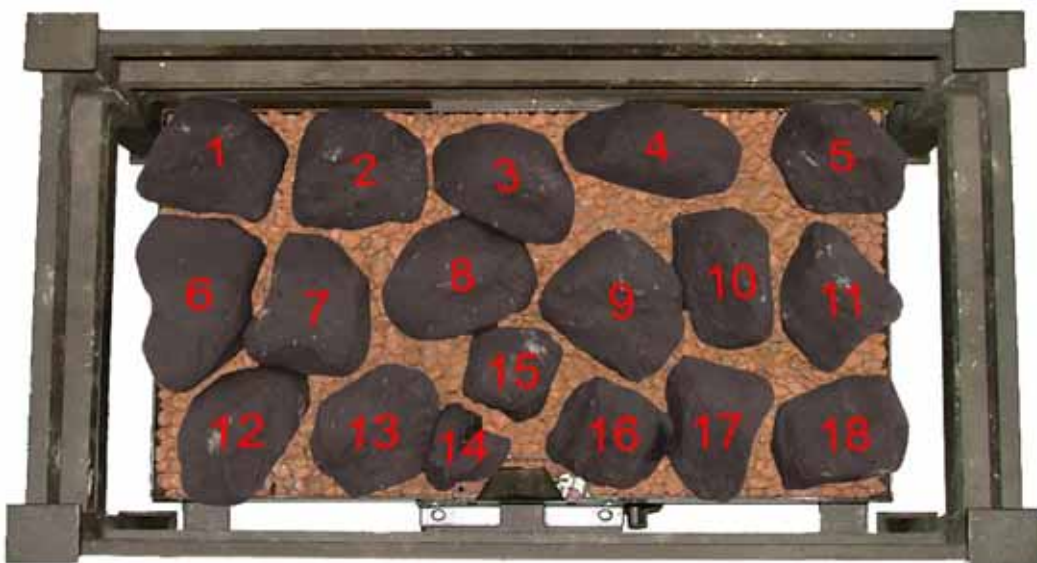

Top layer



There are 5 logs for the 22" basket burner. (Natural Gas Only)

Log Placement

Base Layer



Embers

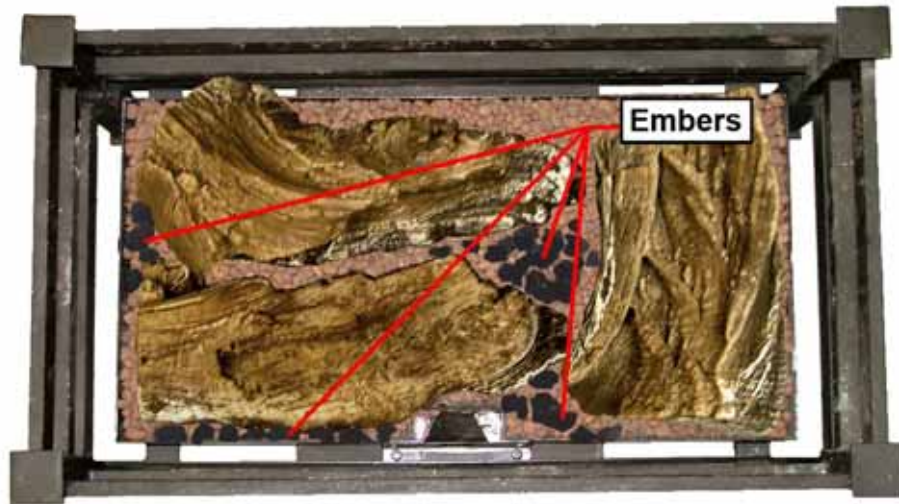

Glow Fibre



Top layer



Layer placement



8. Commissioning the fire unit

Turn on the gas supply

Check the gas supply and gas unit for soundness.

Light the appliance and check that all available functions work correctly. (See 'Lighting the appliance' in User Instructions for information).

Spillage checks

A spillage check must be done before the installed appliance is handed to the customer.

The appliance must be fully fitted, all doors and windows closed in the room in which the appliance is fitted. The appliance is to be tested after 5 minutes of the burn on maximum position.

Light a smoke match and position flush with the fireplace opening testing around the opening a minimum of 50mm from the sides and a maximum of 50mm from the top.

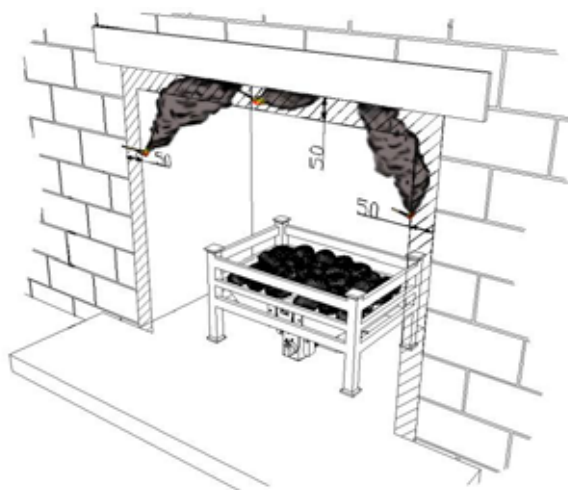

If the chimney is functioning correctly all smoke should be drawn into the chimney and out of the room.

If this does not happen, check after a further 5 minutes of burn time on high rate.

If the smoke still does not expel all fumes then the unit is to be disconnected and expert advice taken.

9. Briefing and handover to the customer

Instruct the customer on the full operation of the appliance.

Warn the customer that the fire unit may give off a harmless and temporary odour; this is normal running in of the unit and will disappear after a short period of use.

Inform the user that rubbish cannot be burned on the unit and not to disturb the fibre coals as this may disturb the combustion.

Inform the customer that it is recommended that a full service on the fire unit and flue checks be carried out annually by competent person/s.

Instruct the customer that the pilot and flame sensing device fitted to the unit also acts as an atmospheric sensing device designed to shut off the appliance if the evacuation of the products of combustion is interrupted. If the appliance cuts off repeatedly then a qualified person is to be informed.

Warn the customer when cleaning the fire unit to use a small brush, and if the coals/logs need cleaning to restore the fibre coals as the layout specified, also advise the customer must not add extra or remove the fibre coals/logs.

Warn the user that the appliance is not fitted with an integral guard. In normal use consideration may be given to the use of a suitable guard conforming to BS8423:2002, such that access to the flame is minimised.

Also advise the user not to stand too close to the appliance for prolonged periods of time; loose clothing is particularly at risk of burning due to the presence of an unguarded flame.

Advise the user against placing combustible material directly in front of the appliance. Floor coverings, such as carpets, are considered to be acceptable.

Ensure the installer details are filled in.

Handover the installation manual to the customer.

10. Servicing

It is advised that the appliance is serviced annually by a qualified person to Local and National Regulations.

Exchangeable components list

Pilot unit (natural gas)	SIT-NG9057
Gas Injector (Natural Gas)	Stereomatic 1.25mm Multi-holed
Control Valve	GV34/GV36/GV60
Clay Granules	
Coal set	
Chesney's 5 piece Log set	

Annual maintenance.

Safety precautions must be taken when cleaning the appliance.

Ensure the appliance is cool before carrying out an annual service.

Isolate the appliance and disconnect the unit.

Always test for gas soundness and spillage after refitting the appliance.

Check all coals/log, pilot burner/ignition unit, for soot or debris deposits.
Replace all misplaced coals and retest.

On the failure of pilot burner/ignition, or control valve have repairs carried out by a competent person.

Pilot Removal

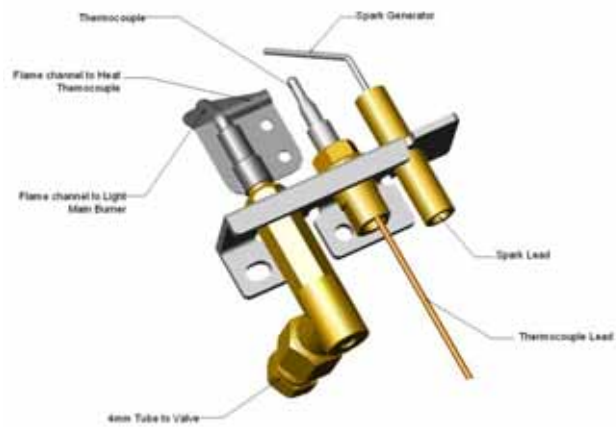

If the pilot is to be exchanged ensure that the part to be fitted is a genuine like for like part.

Isolate the fire unit.

Remove all coals/logs.

Disconnect the main 8mm gas supply pipe from the control valve.

Remove appliance fixings.

Undo and remove the thermocouple nut from the rear of the control valve, disconnect the spark piezo lead from the pilot.

Undo and remove the 4mm gas supply pipe from the pilot and remove the 2 screws attaching the pilot to the burner

Replace with the genuine part and refit in reverse order.

Commission the appliance

Control Valve Removal

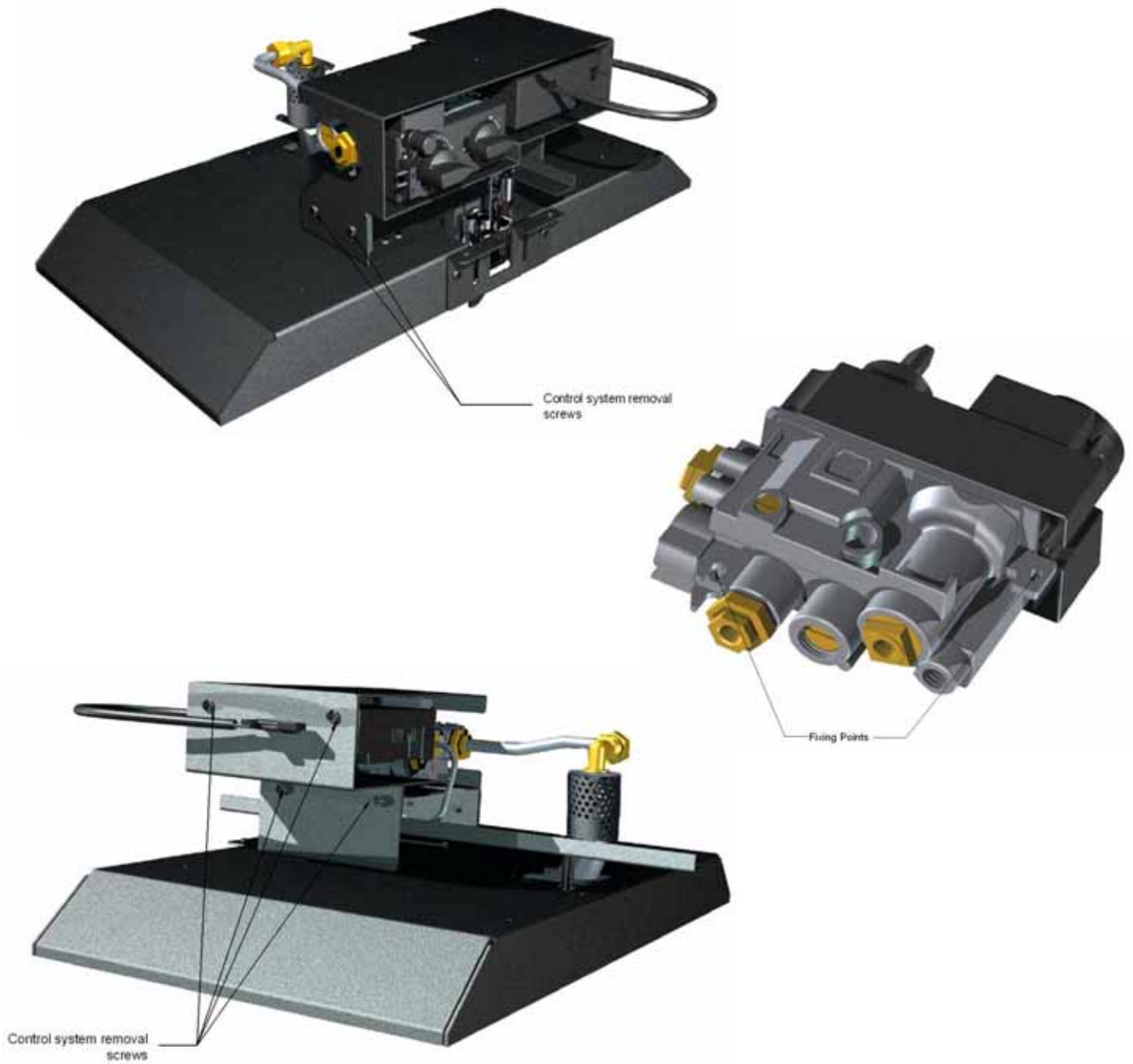

If the Control valve is to be exchanged ensure that the part to be fitted is a genuine like for like part.

NOTE – The valve must be purchased from a Chesney's supplier as the valve needs to be set.

Isolate the fire unit.

Remove all coals/logs and clay granules.

Disconnect the main 8mm gas supply pipe from the control valve.

Remove appliance fixings.

Undo and remove the thermocouple nut from the rear of the control valve, disconnect the spark piezo lead from the pilot.

Undo the Injector pipe (O.D. 8mm)

Remove the pilot gas supply pipe (O.D. 4mm)

Remove wiring plugs.

Remove the control valve by undoing the securing screws.

Remove any wiring attached.

Replace and refit the genuine set part in the reverse order.

Commission the appliance.

11. Fault finding

Symptom	Check List
Unit does not respond.	Check Remote is working properly
	Check Battery power supply.
	Check wiring is correct
Remote does not work.	Check Battery Power.
	Check Remote eye is visible and facing in the correct position. (GV60 Only)
Hardwire switch does not work.	Check Switch is wired properly.
Unit clicks but no spark or weak spark.	Check spark lead is connected properly.
	Check spark electrode is in the correct area and the gap correctly distanced.
Unit sparks but does not light pilot.	Check for a good spark.
	Check the spark is in the correct area.
	Check if the ventilation is not too strong.
	Check if there is gas running through.
If there is no gas.	Check isolation tap/shut off valves are free from grease.
	Check isolation tap/shut off valve/s are on.
	Check for blockages
If there is gas but pilot does not light	Check pressure is correct.
	Check for blockages.
	Check for draughts.
	Check the pilot gas slots are clear.
Pilot lights but does not light main burner	Check the pilot flame is heating the thermocouple.
	Check the thermocouple nut is properly tightened into the valve/interrupter block.
	Check that the pilot lights early on ignition clicks.
	Check ventilation is not too strong.
Burner lights but turns off after a few minutes	Check thermocouple nut is properly secured to the interrupter block (GV60) or into the valve.
	Check ventilation is not too strong and the flame is not blowing off the thermocouple.
	Check gas pressure is correct.

The GV60 fully remote controlled system has audible beeps to indicate a problem with the system.

	Reason
No Beep	Impulse magnet not operating properly – Replace gas valve
1 Long Beep	ON (1)/OFF(0) Switch is on OFF position – Switch to ON (1) <div style="text-align: center; margin-top: 10px;">  <p>ON(1)/OFF(0) Switch</p> </div>
3 Short Beeps	Low Batteries – Replace receiver batteries with 4x1.5V "AA" quality alkaline batteries

12. User Instructions

General

The flue must be fitted in accordance with National Regulations, damper plates or flue restrictors must be removed or fixed permanently in the fully open position.

The chimney should be swept before the appliance is installed.

The flue must not be shared with any other appliance.

After installation the chimney should be regularly swept and inspected, to check that all of the combustion products are entering the flue and that there is no build up of soot.

It is highly recommended that a full service on the fire unit including flue checks be carried out annually by competent person/s.

The gas connection must be in accordance with National Regulations.

Installation and servicing must be carried out by a competent person in line with relevant regulations.

This appliance is intended for decorative purposes. Any purpose-provided ventilation should be checked regularly to ensure that it is free from obstruction.

The appliance is not fitted with an integral guard. It is recommended that a guard be used for the protection of young children, the elderly or infirm and also for normal use conforming to BS8423:2002, such that access to the flame is minimised.

Ensure curtains and soft furnishings are not positioned above the fire opening with at least a clearance of at least 300mm above and 150mm on either side of the fire opening.

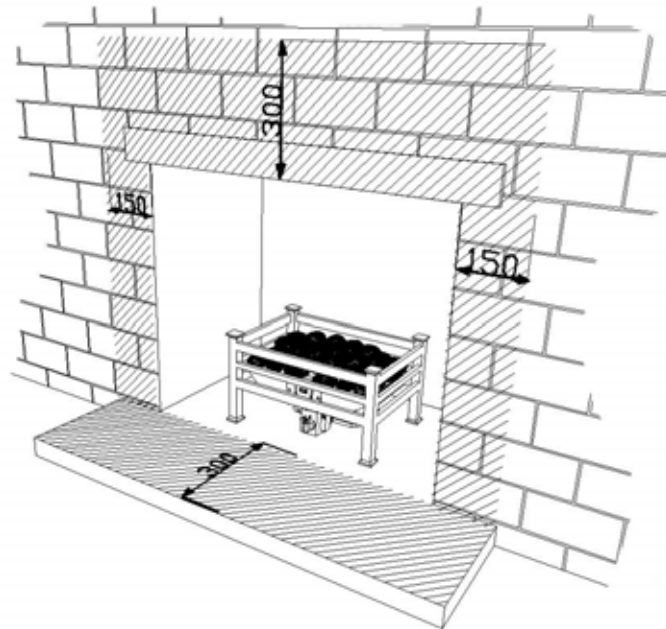

Do not throw rubbish upon the surface area or otherwise disturb the fuel bed. Debris from any source, or soot formed, should be removed from time to time.

The pilot light and flame sensing device fitted to this fire is also an atmosphere sensing device, which shuts off both the main burner and pilot if evacuation of the combustion products is interrupted. If the fire is extinguished or goes out in use, allow 3 minutes before attempting to relight following the lighting sequence stated in 'Lighting the appliance' (Pages 48 to 53). If the fire shuts itself off repeatedly, do not use the fire, and have the flue and fire checked by a suitably qualified person.

The appropriate size and type of ventilation into to the room where the appliance is to be fitted should also take into account any other gas appliances in the room and must comply with Local and National Regulations. The ventilation should be checked on a regular basis to ensure there is no obstruction.

Lighting the appliance (GV34/GV36)

Ensure the left control knob is pointing to the off position, and the right control knob is turned to the high position.



Firmly push the left control knob in and turn counter-clockwise until a click is heard, whilst held in check to see if the pilot is lit and hold in for 10 seconds (If the pilot is not lit repeat the operation). Gently release, if the knob does not pop up when released, STOP and immediately call your service technician or gas supplier. If the pilot will not stay lit after several tries, turn the gas control knob to "OFF" and call your service technician or gas supplier. (If the pilot goes out repeat the procedure).



Turn the appliance to the lighting position.



Use either the handset (GV34 Models) or manually turn the knob on the right side to high rate for 5 to 10 minutes to heat up the appliance and chimney. After this time the unit can be adjusted between HIGH and LOW.



To put the gas control into the pilot position turn the right control knob to the position shown below.



Turning the gas appliance off (GV34/GV36)

Set the right control knob to the high position, and the left control knob to the OFF position.



After turning the appliance off, the gas left in the burner will continue to burn making popping and crackling noises for around 30 seconds this is normal.

GV60 Lighting

GV60



If the GV60 control unit makes a long beep the on/off switch is set on the OFF (0) position, switch the unit to the ON (1) position.

The GV60 is fully remote controlled. (The GV60 is only available in Infra-red for safety regulations).

When lighting the fire the remote control must have 'line of sight' to sensor.

The Infra-red remote sensor is situated close to the fire unit; the placement may differ depending on the type of fire basket.

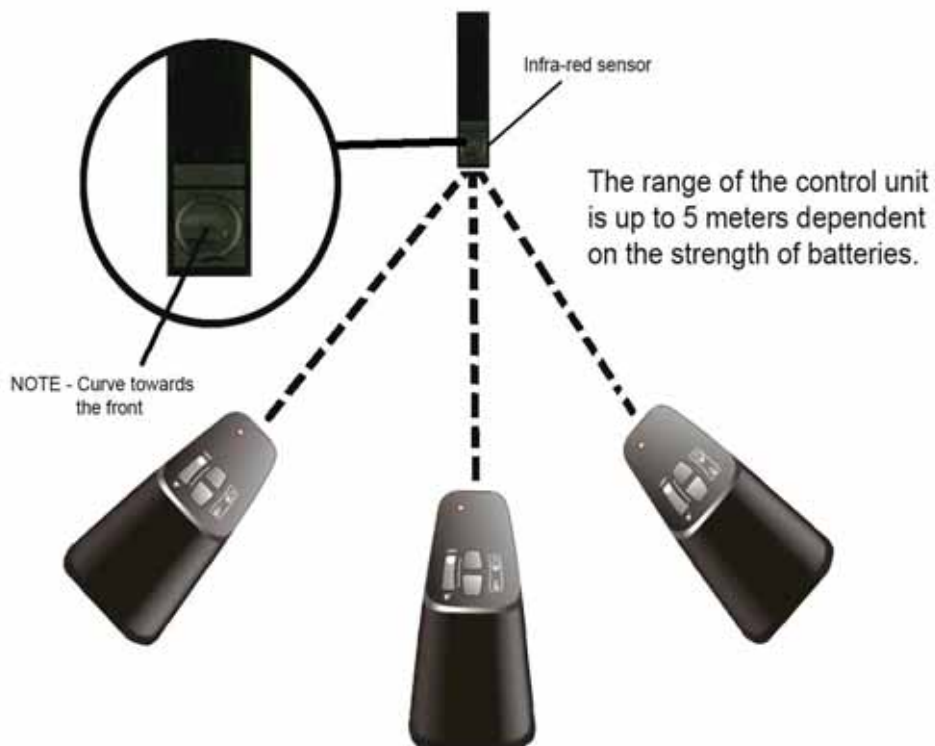

To light a fire with a GV60 fitted is different to the GV34/GV36.
The fire unit can be lit using the remote control handset.

To light the fire unit you must press and hold both buttons ✧▲ (star, up arrow) and the small lower button until a short acoustic signal confirms the start sequence has begun; release buttons. Continuing signals confirms the ignition is in process. The fire unit will then light on High rate; if the fire unit is cold it is advised to leave the burner on high rate for at least 5-10 minutes to warm up the flue before turning between the 'High and Low rates.



When the fire has warmed the flame height can be adjusted between 'High and Low' by pressing either both the ✧▲ (up arrow) to increase flame height, or pressing the ▼ (down arrow) to decrease flame height.
The pilot can just remain lit this is done by holding the ▼ (down arrow) until the fire unit turns off the main burner.
To go from the lit pilot to main press both the ✧ ▲ (up arrow).
To turn off the fire unit completely press the off button.

Lighting the appliance with a match

GV34/GV36 Control Valves



If the pilot does not ignite as described in 'Lighting the appliance', it may be lit with a match.
Firmly push the left control knob in and rotate counter-clockwise until the knob is pointing at the pilot position.



Whilst holding the knob in, apply a lighted match to the pilot area circled below.

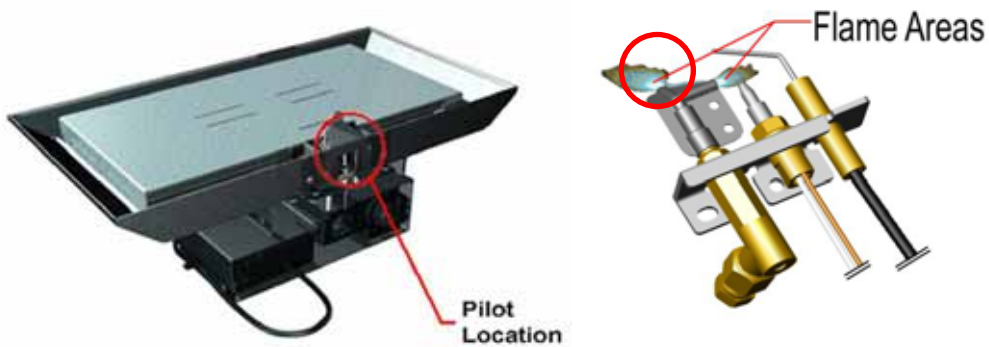

Once lit keep the knob pushed in for 5 to 10 seconds and then release, the pilot should remain alight.
The pilot can then be turned to the 'Lighting' position as previously described.

GV60 Control Valve

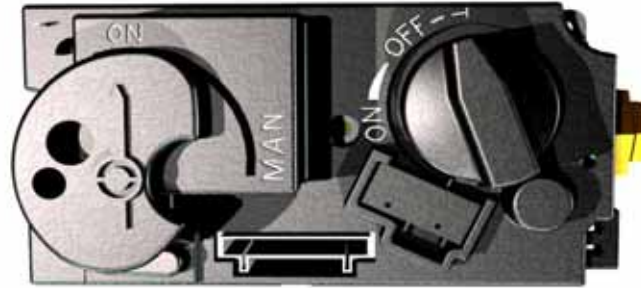

Start the fire with the control handset when the acoustic signal confirms the start sequence hold the lighted match to the pilot area circled below right.

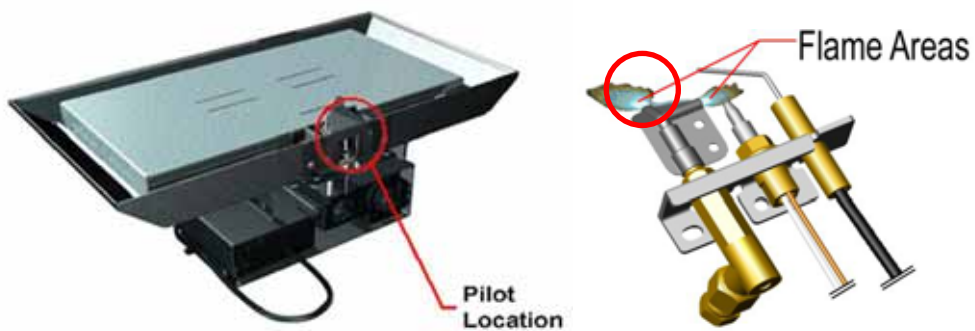

Once the pilot is lit leave the fire unit finish the sequence.

If the fire is extinguished or goes out in use, allow 3 minutes before attempting to relight following the lighting sequence stated in 'Lighting the appliance'.

If the fire shuts itself off repeatedly do not use the appliance, and have the flue and fire appliance checked by a suitably qualified person.

Changing the batteries (GV34 / GV60)

The batteries will require changing yearly (based on the average usage) this may differ depending on usage and on the quality of battery, the battery change is best done on the annual service of the appliance.

However if the appliance is showing signs of diminishing signal or during the lighting sequence then the batteries may need changing.

Firstly replace the handset battery before attempting to change the fire unit battery.

Remote handset battery

1 x 9V block
(Quality alkaline recommended)



Receiver batteries

4 x 1.5V "AA"
(Quality alkaline recommended)

An AC Mains Adapter may be used instead of batteries (only the Mertik Maxitrol AC Mains Adapter or one approved by Mertik Maxitrol can be used).

NOTE: During a power outage the AC Mains Adapter must be unplugged from the receiver to operate in battery mode.



Ensure to follow direction of the batteries (indicated in the compartment). Check the connections are secure before replacing the box back into the burner unit.

Cleaning

Cleaning should only be carried out when the fire is turned off and cold.

It is necessary to clean the fire if debris or soot deposits have accumulated on the coals/logs.

A soft brush is advised to clean the coals/logs and burner unit.

NOTE – Do not use a vacuum cleaner the coals/logs or burner unit.

When placing the coals/logs ensure they are placed as the layout. (See pages 34 to 38).

Fuel bed components

The ceramic parts are fragile; care must to be taken when handling this product.

When placing the coals/logs it is important to carefully follow the layouts in this manual, the layout has been set to give the best performance and flame picture of the appliance.

Do not use any more ceramic components than those shown, extra parts supplied are spares for future use.

Ceramic components should last around 2 years in normal use at which time is recommended that they are replaced.

Replacements can be bought from any Chesney's stockists. State the model number (found on the gas fire data plate).

Always ask for genuine Chesney's parts.

This appliance is manufactured by -

Chesney's Limited

194 – 200 Battersea Park Road,

London, SW11 4ND

Tel: 020 7627 1410 Fax: 020 7622 1078

13. Installer Check List

FLUE CHECKLIST	PASS	FAIL
Flue Size		
Flow test		
Spillage test		
GAS CHECKLIST	PASS	FAIL
Soundness		
Standing Pressure		
Working Pressure		
VENTILATION	PASS	FAIL
Ventilation requirements for appliance		

14. Dealer and Installer Information

DEALER AND INSTALLER INFORMATION	
Dealer	Installation Company
Contact No.	Gas Safe Engineer
Date of Purchase	Contact No.
Model No.	Gas Safe No.
Serial No.	Date of Installation
Gas Type	

15. Annual Service Record

Annual service record Year 1

Gas Safe Engineer
Contact No.
Gas Safe No.
Date of Service

Annual service record Year 2

Gas Safe Engineer
Contact No.
Gas Safe No.
Date of Service

Annual service record Year 3

Gas Safe Engineer
Contact No.
Gas Safe No.
Date of Service

Annual service record Year 4

Gas Safe Engineer
Contact No.
Gas Safe No.
Date of Service

Annual service record Year 5

Gas Safe Engineer
Contact No.
Gas Safe No.
Date of Service

Annual service record Year 6

Gas Safe Engineer
Contact No.
Gas Safe No.
Date of Service

16. Chesney's Warranty Registration

To validate and start your warranty please fill out this form and send it back to:

Chesney's Warranty Registration
521 Battersea Park Road
London
SW11 3BN

Alternatively, log on to:
<https://secure.chesneys.co.uk/warranty/registration.asp> and complete the online form.

All items are required:

Your Details	
Name	
Address	
Postcode	
Email address	

Purchase Details	
Purchased From	
Purchase Date	

Product Details	
Appliance name	
Appliance colour	
Serial number	